



**Service Bulletin**

**Service Bulletin:** SB222-200; Bell 222 Air Conditioner Condenser Blower Replacement.

**Subject:** Air conditioning system condenser blower and motor assembly change.

**Date:** 10 July, 1998

**Applicability:** Bell Helicopter Model 222 Series

**Reference:**

1. F.A.A./S.T.C. # SH5225NM, Bell Helicopter 222 Series Air Conditioning System.
2. Condenser Installation Drawing # : 222AC-700
3. Condenser Assembly Drawing # : 222AC-7000
4. Electrical Installation Drawing # : 222AC-800

**Compliance:** At the desecration of the operator, or on the failure of the existing blower / motor assembly.

**I. Discussion:**

The condenser blower motors installed in the Bell 222 air conditioning system have become obsolete, and It has become necessary to provide an alternate condenser blower assembly. The new condenser blower assembly will be offered as a replacement for previous installations as the blower motor assembly become inoperative.

**II. Approval:**

The technical aspects of this service bulletin have been FAA / DER approved.

**III. Purpose:**

This Service Bulletin provides a change to the condenser blower motor and fan assemblies to insure the continued service life of the air conditioning system.

**IV. Bill of Materials:**

| Qty. | Part Number | Nomenclature                    |
|------|-------------|---------------------------------|
| 2    | ES73186-4   | Condenser (pusher) Blower assy. |
| 8    | AN3H-3A     | Bolt                            |
| 16   | AN970-3     | Washer                          |
| 2    | 320570      | Butt Splice Connector           |
| 4    | CT4B        | Tywrap                          |

JUL 07 2004

Ans'd.....

## V. Removal and Replacement of the Condenser Blower Fan Assembly.

### NOTE

Disconnect battery and external power before starting work.

1. Remove the center belly panel to gain access to the air conditioner condenser blower assembly.
2. Cut the electrical wires to the condenser blower motor assemblies at the existing butt splice connection. Being sure to mark the positive and ground wires for proper identification during the installation of the new blower assemblies.
3. Remove the two retaining bolts and washers from the 222AC-7000-14 condenser support bracket (outboard), and the two bolts and washers from the S-7512EC-2 angle (inboard) to remove each of the obsolete S-7022EC-3 blower assemblies from the condenser housing.
4. Install the new ES73186-4 condenser blower assemblies using the existing 222AC-7000-14 support bracket and S-7512EC-2 angle, use four each of the AN3H-3A bolt and eight each of the AN970-3 washer. It will be necessary to preinstall the two inboard bolts and washers on each of the blower housings to facilitate their installation into the S-7512EC-2 angle. Placing one of the AN970-3 washers between the bolt head & the angle, and a second between the angle and the blower housing. The remaining bolts and washers may now be installed in the same manner through the 222AC-7000-14 (outboard) support bracket. Tighten bolts and safety using .032 safety wire.
5. Connect the red (positive) wire from each of the ES73186-4 blower motors (in parallel) to the existing air conditioner power supply wire.
6. Connect the Black (ground) wire from each of the ES73186-4 blower motors (in parallel) to the existing air conditioner ground wire. Secure all loose wiring using the provided Tywraps prior to operating the system.
7. Reconnect the battery or external power supply and check the operation of the blower assemblies. Note: the blowers should be pushing the air through the condenser assembly.
8. After the maintenance operational check of the condenser blower motors has been completed reinstall the center belly panel in the reverse order of its removal.

**Weight & Balance:** There is a negligible change to the weight of the new blower motor assembly as compared to the ones being removed.

JUL 07 2004

Ans'd.....

**Electrical Considerations:**

The electrical loading of the motors installed in the ES73186-4 are 1.5 Amps (3.0 combined) less than that of the current blower motor, therefore, the electrical load margins, existing wire size and circuit breakers are acceptable.

**Electrical System:**

On completion of the blower installation it will be necessary to perform an EMI / RMI test with the air conditioning system running. This is to insure that there are no adverse effects with regards to interference with the navigational, communication, or cockpit instrumentation.

**Test Procedure:**

- Switch the air conditioner system from off to on.
  - Monitor the engine and navigation instrumentation for any adverse deflections.
  - Monitor the communication equipment for any audio interference.

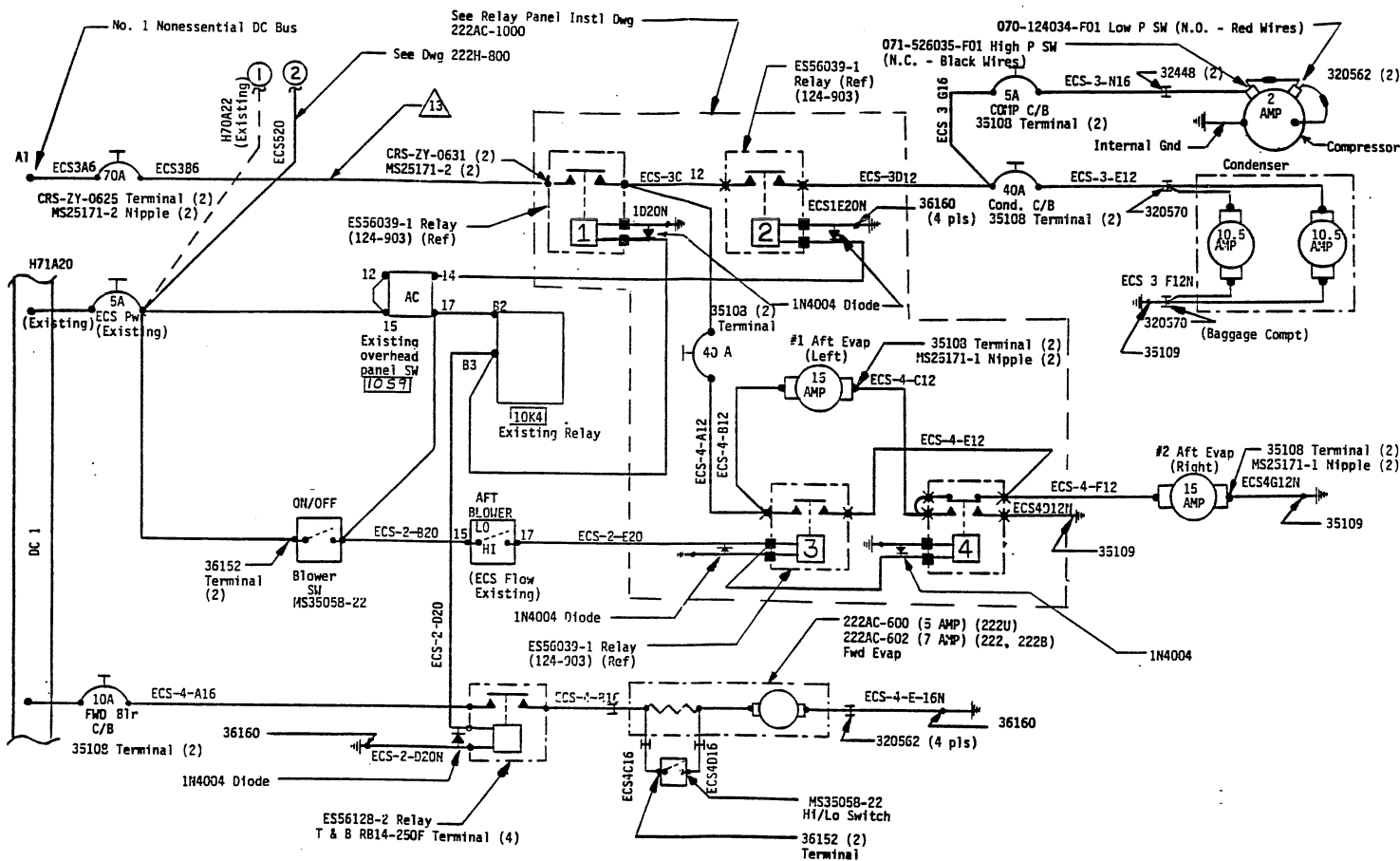

This area intentionally left blank

JUL 07 2004

Ans'd.....

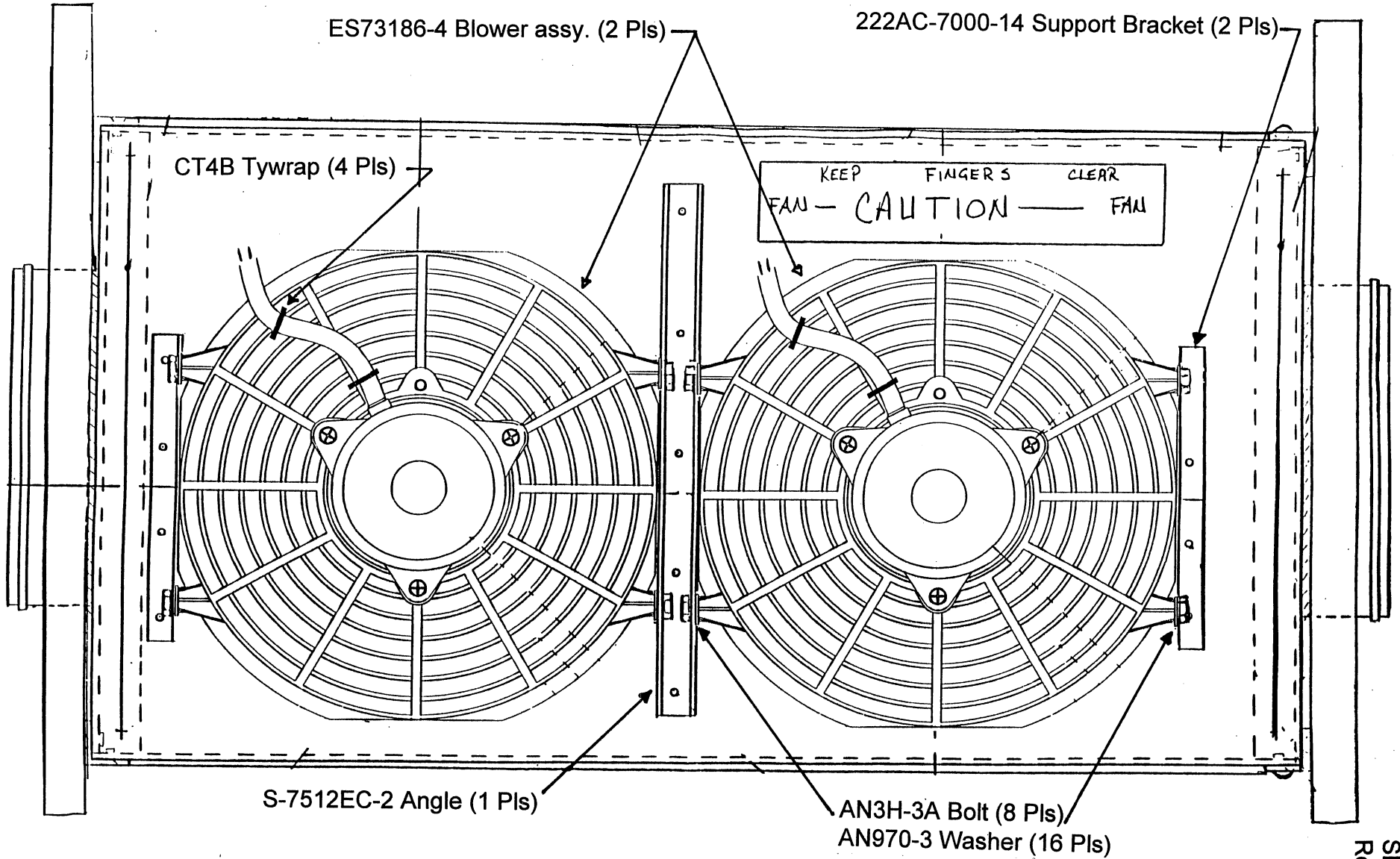

VIEW LOOKING UP 222AC-7000 CONDENSER ASSEMBLY

JUL 07 2004  
Ans'd.....

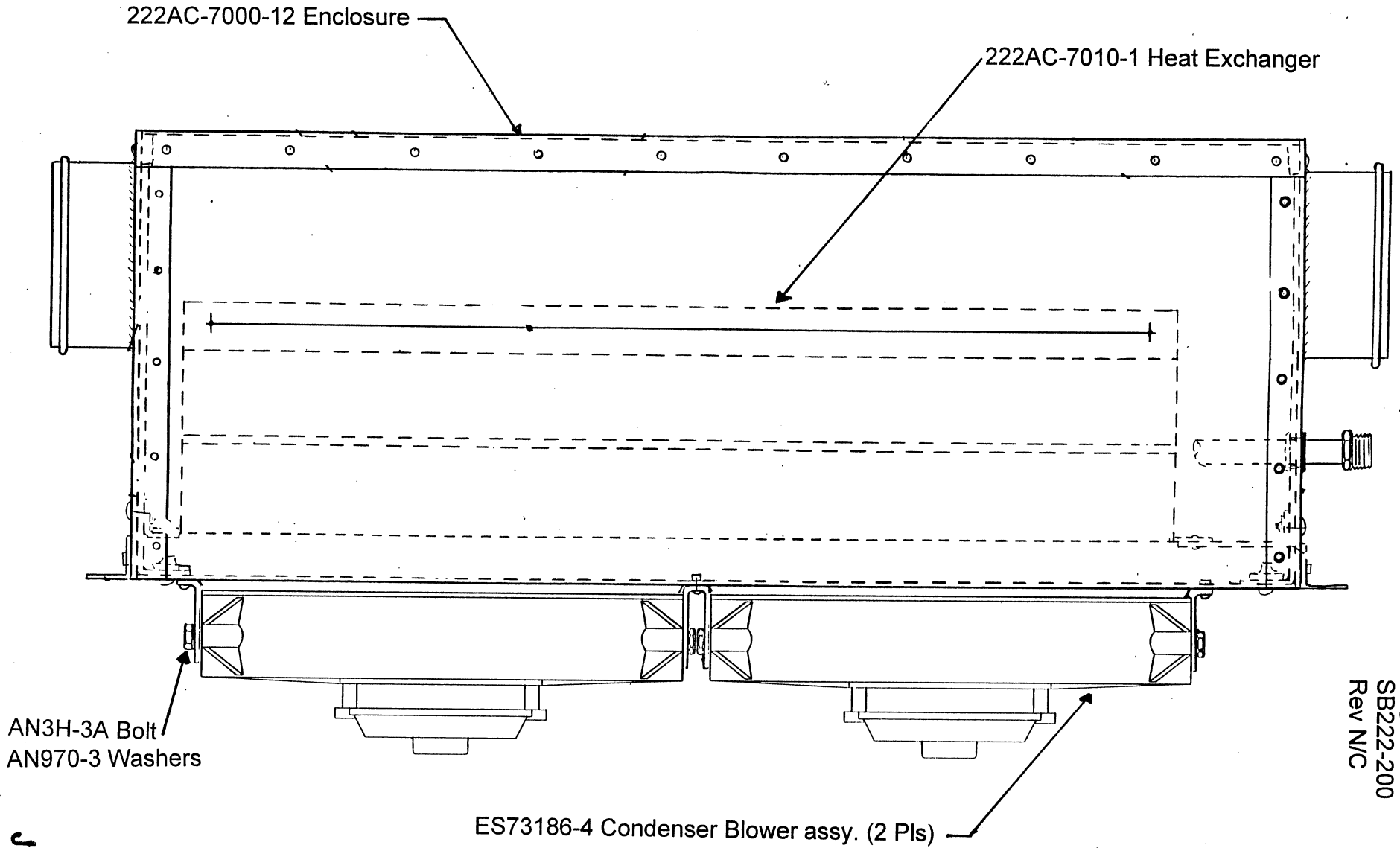

Page 5 of 5  
SB222-200  
Rev N/C

SIDE VIEW 222AC-7000 CONDENSER ASSEMBLY

JUL 07 2004

Ans'd