

AIR COMM CORPORATION
3300 AIRPORT ROAD
BOULDER, CO 80301

105H - 300M

SERVICE INSTRUCTIONS:
BO105 CABIN HEATER/TUNNEL HEATER
SYSTEMS

December 28, 1992

Table of Contents

<u>Item</u>	<u>Page No.</u>
System Description.....	1
References.....	2
Figure 1. Air Distribution and Control.....	3
Figure 2. Heater Controls.....	4
Figure 3. Cabin & Tunnel Heater System.....	5
Figure 4. Tunnel Heater System.....	5
ACC Spaces List.....	6
Maintenance Schedule.....	6

SYSTEM DESCRIPTION

The ACC Cabin Heater is a bleed air type which can be installed as a basic cabin heater, or as a "tunnel" heater system.

The ACC system configurations are defined by the following ACC part numbers:

105H-100-2; Cabin Heater System Installation

105H-100-3; Tunnel Heater System Installation

These systems utilize some components of the "factory approved" heater system and therefore MBB Service Instructions for the 105-810004 Heater System is considered to be applicable.

The basic heater system, as shown by figure 3, includes both cabin and "tunnel" heaters.

An alternate configuration, as shown by figure 4, consists of only the "tunnel" heaters, and is intended to be installed in combination with the factory installed cabin heater system.

The systems are operated by moving the ECU master switch to ON and rotating the temperature control knob to the desired position.

The following features apply to both the basic cabin heater system, and the factory heater - ACC tunnel heater configuration.

The fresh air/recirculate air selector lever located on the left side of the switch panel permits fresh air or recirculated air to be mixed with the bleed air. Selection of fresh air is to be used for side window defogging and selection of recirculated air provides maximum heating.

Fresh air is available during forward flight by moving the fresh air/cabin air selector lever to the fresh air position.

The system incorporates a duct overheat sensor. When the overheat sensor detects duct temperature above $80 + 5^{\circ}$ C, the caution light DUCT HOT located on the annunciator panel illuminates and the shut-off valves will be closed automatically.

REFERENCES

1. Air Comm Corporation STC No. SH5253NM.
2. Air Comm Corporation Drawing No. 105H-100; B0105 Heater/
Ventilation system.
3. MBB Services Instructions for 105-810004 Cabin Heater
System.
4. MBB Service Instructions for 105-809824 ECU System.

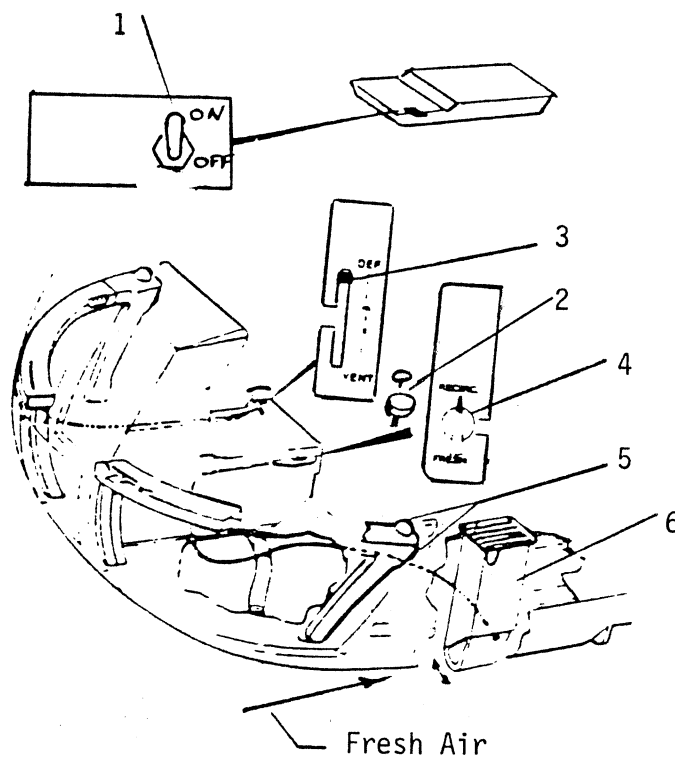

Fig. 1 Air Distribution and Control

- 1 ECU master switch
- 2 Heater temperature control knob
- 3 Windshield defog/ventilation selector lever
- 4 Fresh air/cabin air selector lever
- 5 Swivel air nozzle
- 6 Air intake duct

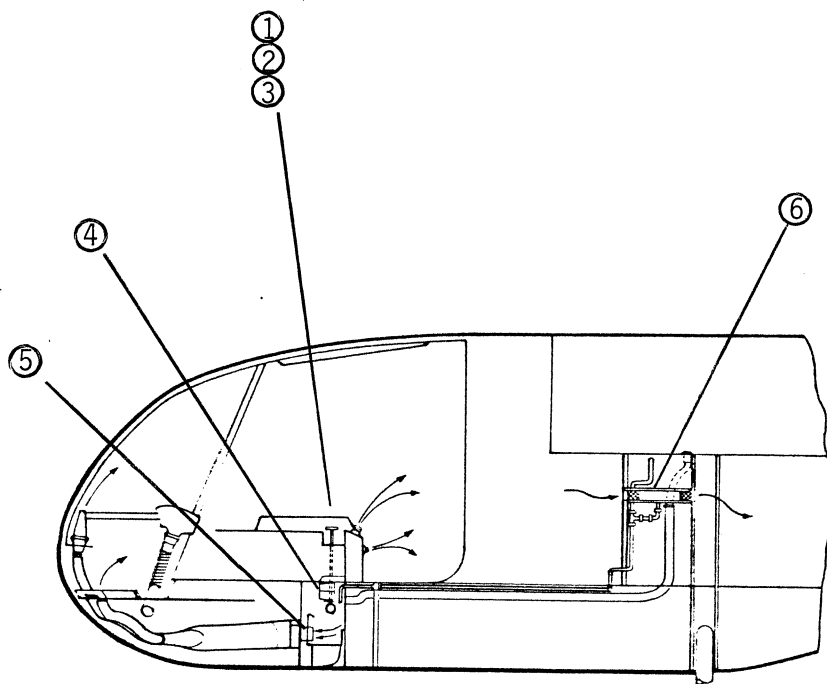

Figure 3. Basic Cabin Heater System (Cabin & Tunnel Htr)

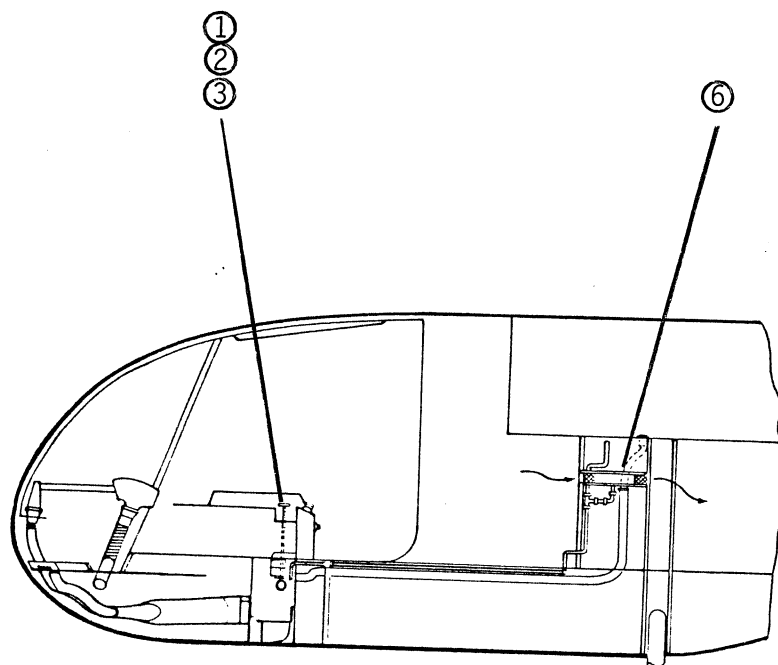

Figure 4. Tunnel Heater System

Spaces List (Figures 3 & 4)

<u>ITEM NO.</u>	<u>DESCRIPTION</u>	<u>P/N</u>
1	Control Knob Placard	222H-9000-20
2	Control Knob	222H-9000-19
3	Heater Valve	ES26172-12
4	Cabin Heater Ejector	222H-9006-1
5	Cockpit Heater Ejector	222H-9006-1
6	Tunnel Heater Ejector	S-6424EC-3

Maintainence Schedule

The following is to be accomplished annually.

1. Remove all Heater Ejectors and inspect for corrosion. Replace as required.
2. Inspect plumbing for evidence of corrosion. Replace as required.
3. Inspect control valve for freedom of operation.
4. Check all plumbing joints to insure that all fittings are tight.
5. Apply "shop air" at fire wall joint to check for system leaks.