

Service Bulletin

Service Bulletin: SB407-3526; Bell 407 Air Conditioner Drive Pulley Bevel Washer Replacement.

Subject: Tail Rotor Driveshaft Bevel Washer Replacement.

Date: 15 Sept 2006
14 Jan 2007 Rev A
09 Feb 2007 Rev B

Applicability: Bell Helicopter Model 407 series equipped with the Air Comm Corporation air conditioner system.

Reference:

1. F.A.A./S.T.C. #SR00222DE ,Bell Helicopter 407 Series Air Conditioning System.
2. Compressor Installation Drawing # : 407EC-300, Rev AF
3. Bevel Washer Drawing #: S-3526EC, Rev C

Compliance: At the discretion of the operator.

I. Discussion:

Field inspections have indicated that some wear maybe occurring between the inside shoulder of the S-3526EC-4 Bevel Washer and the base of the NAS6605 Bolt head on Bell 407 Helicopters equipped with an Air Comm air conditioner system.

This hardware is located just forward of the air conditioner drive pulley, and retains the tail rotor disc pack coupling assembly to the tail rotor drive shaft.

To comply with this Service Bulletin it will be necessary to remove and replace the hardware indicated as follow.

II. Approval:

Technical aspects of this Service Bulletin are FAA / DER approved.

Rev A: S-3526EC-7 replaces the S-3526EC-4 or -6

Rev B: AN960-516 shown under nut on tail rotor drive shaft flange

III. Purpose:

The purpose of this bulletin is to remove, and replace the affected existing attaching hardware from the disc pack coupling just forward of the air conditioner drive pulley.

IV. Weight and Balance:

No change.

V. Installation Configurations:

ACC Installation Number	Disc Pack Configuration	Effective aircraft serial number	Notes:	Reference page number of this SB.
-1A	Round	53000 - 53319	Original configuration - FWD located flywheel & round disc pack.	NA
-1B	Star	53320 - 53442	Includes S/N 53000 - 53319 if updated by optional BHT TB 407-99-18.	NA
-2	Star	53443 - 53497	New blower shaft with aft located flywheel.	Page 5 of 6
-3	Star	53498 - Subsequent	Added balance plate to blower shaft coupling.	Page 6 of 6

VI. Bill of Materials:

Parts to be Removed

Configuration	Part Number	Description	Quantity
-2	S-3526EC-4 or -6	Bevel Washer	4
	NAS6605-8	Bolt	2
	MS21042L5	Nut	4
*	*	*	*
-3	S-3526EC-4 or -6	Bevel Washer	4
	NAS6605-10	Bolt	2
	MS21042L5	Nut	4

Bill of Materials (continued)

Parts to be Installed

Configuration	Part Number	Description	Quantity
-2	S-3526EC-7	Bevel Washer	4
	NAS6605-8	Bolt	2
	MS21042L5	Nut	4
*	*	*	*
-3	S-3526EC-7	Bevel Washer	4
	NAS6605-10	Bolt	2
	MS21042L5	Nut	4

Contact the ACC Service Department to obtain the parts listed above at no charge to complete this Service Bulletin at: Phone 303-440-4075, Fax 303-440-6355, or E-mail at info@aircommcorp.com

VII. Accomplishment instructions:

NOTE

It is not necessary to discharge the air conditioner system, or loosen the compressor drive belt to accomplish this Service Bulletin.

1. There are four distinct installation configurations for the disc pack hardware which is mounted just forward of the air conditioner compressor drive pulley. Only two are affected by this bulletin. Only the installations that used a bevel washer directly under the bolt heads are affected. The other, earlier versions, used a spacer between the Bell p/n 407-040-316-101 flywheel and disc pack under two bolts and are not affected by this service bulletin. It is important to identify the correct installation dash number in order to procure and install the proper hardware to complete this Service Bulletin. See Section V. Installation Configurations (Page 1 of 6) to select the correct Bill of Materials to install.

2. Remove, and discard the hardware shown in section VI. Bill of Materials, **Parts to be Removed** according to the configuration which is appropriate for your aircraft (-2, or -3).

Continued:

Accomplishment instructions (continued):

3. Install the hardware shown in section VI. Bill of Materials, **Parts to be Installed** according to the configuration which is appropriate for your aircraft (-2, or -3). Inspect the other components to be reused for satisfactory condition and reinstall if found satisfactory. Replace unsatisfactory components.

4. Torque all fasteners in accordance with the specific Applied torques shown on the face of the illustrations for the appropriate configuration (-2, or -3).

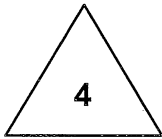

CAUTION

The recommended standard torque range is given in the following drawings.

***Tare "Drag" Torque shall be added to the torque value listed unless otherwise stated.**

** Tare Torque. Is the torque required to overcome resistance of self locking nuts against a mating bolt, screw, or stud threads. Tare torque must be measured using the same fastener combination that the torque will be applied to. Tare torque is unique to each fastener combination.*

The preferred method for measuring tare torque is to use a dial indicator type torque wrench, but may be measured by approaching the value with a "click" style torque wrench. The measured value must be compared to the Minimum Tare Torque Value. If the measured value is less than the minimum listed, the lock nut must be replaced.

*** Applied Torque. The total torque value applied to a fastener. Applied torque is the Standard Torque or Specified Torque, plus the Tare Torque. It is unique to the fastener combination, so an adjacent fastener combination utilizing the same hardware may require a different applied torque value.*

It is not acceptable to measure tare torque for one fastener combination and apply this tare torque value to all similar fasteners. Variations in wear, stress, and finish will impact tare values of fasteners of the same size and type.

This area intentionally left blank

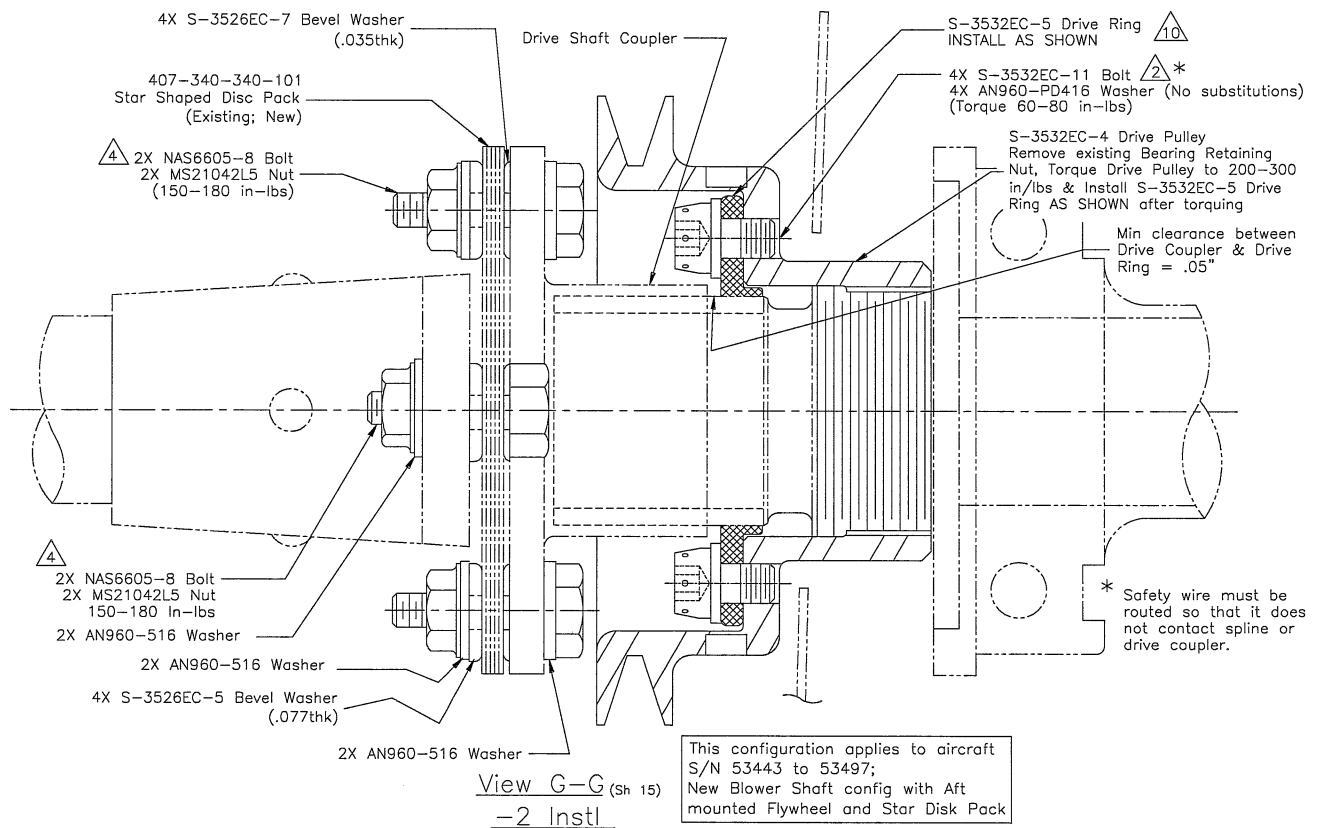

Installation Configuration -2 (Installation of S-3526EC-7 Bevel Washers)

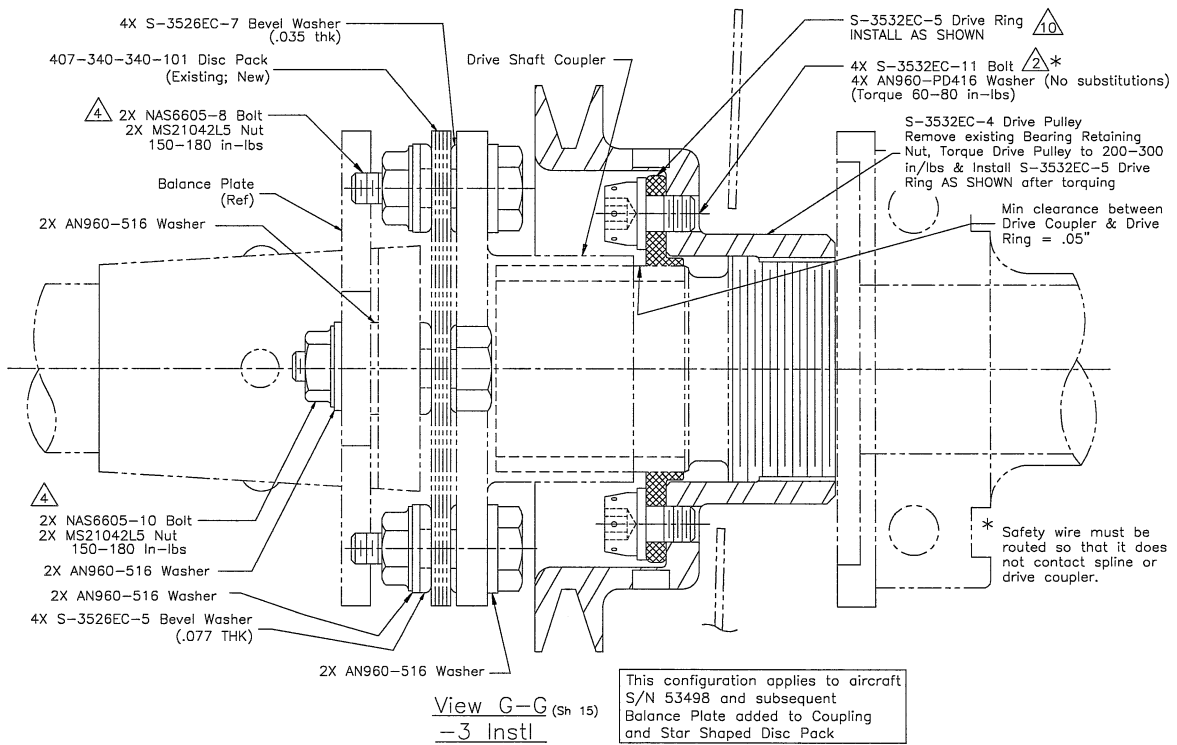

Installation Configuration -3 (Installation of S-3526EC-7 Bevel Washers)