

AIR COMM CORPORATION
Boulder Municipal Airport
3300 Airport Road
Boulder, CO 80301

Report 407H-200M-2

BELL 407 SERIES CABIN HEATER SYSTEM
INSTALLATION INSTRUCTIONS
(AM Configuration)

January 15, 1996

This document contains:
Flight Manual Supplement
STC Certificate
Service Instructions

Revisions

<u>Rev</u>	<u>Description</u>	<u>Date</u>	<u>Appl</u>
A	Revised Page IV-1 to show revised weight & Balance data. Added page 9 in the Instructions for Continued Airworthiness.	5-9-96	NS
B	Added note 9, to page III-1	4-21-97	

Table of Contents

<u>Item</u>	<u>Page</u>
Revisions	i
Introduction	I-1
References	I-1
Installation Instructions - Basic Heater System	II-1
Installation Instructions - Defroster System	III-1
Weight and Balance Data	IV-1
Flight Manual Supplement	V-1
STC Certificate	VI-1
Instructions for Continued Airworthiness	VII-1

Introduction

This document presents a step-by-step procedure for installation of the ACC 407H-201/203 Cabin Heater Systems in the Bell 407 Series Helicopter. The instructions contained herein are intended to supplement the information contained on the installation drawings.

This manual provides additional information which is required for operation and maintenance of the aircraft. This data is contained in sections V, VI, and VII. After completion of this installation, the applicable sections are to be removed from this document, and placed with the appropriate existing documents.

References

1. ACC Drawing 407H-201; Bell 407 Series Cabin Heater Installation. (Standard Heater)
2. ACC Drawing 407H-203; Bell 407 Series Cabin Heater Installation. (Arctic Heater)
3. ACC Drawing 407H-500; Bell 407 Engine Compartment Bleed Installation.
4. ACC Drawing 407H-518; Bell 407 Bleed Air Plumbing Installation. (Standard Heater)
5. ACC Drawing 407H-522; Bell 407 Bleed Air Plumbing Installation. (Arctic Heater)
6. ACC Drawing 407H-921; Bell 407 Series Heater Ejector Installation. (Standard Heater)
7. ACC Drawing 407H-922; Bell 407 Series Heater Ejector Installation. (Arctic Heater)
8. ACC Drawing 407H-960; Windshield Defroster Installation
9. ACC Drawing 407H-988; Chin Bubble Defog Installation (optional).
10. AC43.13.1A; Acceptable Practices, Aircraft Alteration and Repair.

Installation Instructions - Basic Heater System

1. Review the system installation drawings and read completely through the Installation Instructions. BE SURE TO READ THE NOTES ON ALL DRAWINGS.
2. Open up the aircraft.
 - a. Remove the upper fairing.
 - b. Open engine cowling.
 - c. Remove both forward seat panels and the panel under the collective stick.
 - d. Remove the cover between the center row of seat.
3. Install Engine Compartment Bleed Air System if not previously completed.
4. Remove cover plates from Ejector Adapter Mounting holes, Dwg 407H-921. (407H-922 for Arctic Heater)
5. Mount heater ejectors per Dwg 407H-921. (407H-922 for Arctic Heater)

Note

Ejectors flow control valve must be indexed as shown on pg 4 & 5, Dwg 407H-921. (pgs 3&4, Dwg 922)

6. Install "heater control" valve as shown by Dwg 407H-201, page 6.

Installation Instructions - Basic Heater System (cont'd)

8. Install plumbing from Engine Bleed Air System and continue on cabin top as shown by plumbing Installation drawing.
9. Locate S-9420EC-24 Doubler as shown on Dwg 407H-521, Pg 6. Drill Hole Through Doubler and Web of Bulkhead. Locate hole to align with AN824-8J Tee. Install GM1 Grommet around edges of hole.
10. Drill tube penetration holes in center console and install GM32 Grommets as shown on the plumbing Installation drawing.
11. Connect remaining heater plumbing and review all notes on drawing.
12. For defroster installation, refer to Dwg 407H-960.
13. Inspect all plumbing fittings and hardware for security.
14. Leak test system as noted on the plumbing drawing. Torque Seal all plumbing fittings.
15. Safety wire all fittings per AC-65-9A.

Installation Instructions - Defroster System

1. Review Dwg 407H-960.
2. Install S-9207EC-1 Defroster valve as shown on sht 7 of Dwg 407H-960.
3. Connect the Tube Assemblies as shown on sht 5, Dwg 407H-960.
4. Locate and enlarge existing tooling hole (Sta 21.5 Bhd) to .812 dia for plumbing penetration.
5. Install remaining tube assemblies as shown on sht 6, Dwg 407H-960.
6. Remove defroster eyebrows and install ejectors per sht 8, Dwg 407H-960. Re-install eyebrows.

Note

- a. Make sure that ejectors are installed with outlet slot oriented aft toward the eyebrow.
 - b. The existing defroster blowers may be retained or deleted. The blowers do not significantly affect the airflow of the ejector system when the blower is installed but not operating.
7. Review all notes on sht 1, Dwg 407-960. Check all fittings and fasteners for security.
 8. Safety wire all fittings per AC-65-9A.
 9. The 407H-988 Chin Bubble Defroster is an option which is installed when required by the customer order. All installation details, and requirements are provided by the 407H-988 drawings.

Bell Model (407 407H-201 & -203) Cabin Heater Weight and Balance Data

Correct the aircraft licensed empty weight and center of gravity data as indicated below:

Cabin Heater / Defroster System - Standard / After Market 407H-201

<u>Item</u>	<u>Description</u>	<u>Wt (lbs)</u>	<u>Arm (in)</u>	<u>Moment (in-lbs)</u>
1	Total - Heater / Defroster System	14.90	69.87	1,041.10
2	Add 407H-500-1 Eng Bleed System (if not previously installed)	3.80	153.0	581.40
3	Total -Htr/Defog with Bleed System	18.70	86.76	1,622.50
4	add optional Chin Bubble Defroster (if Installed)	.60	22.0	13.20
5	TOTAL (items 3, & 4)	19.30	84.75	1,635.70

Cabin Heater / Defroster System - Arctic / After Market 407H-203

<u>Item</u>	<u>Description</u>	<u>Wt (lbs)</u>	<u>Arm (in)</u>	<u>Moment (in-lbs)</u>
1	Total - Heater / Defroster System	16.20	69.96	1,133.30
2	Add 407H-500-1 Eng Bleed System (if not previously installed)	3.80	153.0	581.40
3	Total -Htr/Defog with Bleed System	20.00	85.74	1,714.70
4	add optional Chin Bubble Defroster (if Installed)	.60	22.00	13.20
5	TOTAL (items 3, & 4)	20.60	83.88	1,727.90

FLIGHT MANUAL SUPPLEMENT

CORPORATION
 3300 AIRPORT ROAD
 BOULDER, COLORADO 80301

Log of Pages

FAA APPROVED
 SUPPLEMENT

MODEL 407
 FLIGHT MANUAL

BELL HELICOPTER
 MODEL 407 250-C47B ENGINE
 FOR

BLEED AIR CABIN HEATER

407H -2

FAA APPROVED

The information contained in this documents FAA approved material, which must be carried in the basic Flight Manual, after the rotorcraft has been modified by the installation of the Cabin Heater System in accordance with Air Comm Corporation STC No. SR00221DE.

The information in this document supplements or supersedes the basic manual only in the items contained herein. For Limitations, Procedures, and Performance Data not contained in this supplement, consult the basic Flight Manual.

FAA APPROVAL March 29, 1996 1 of 10

BLEED AIR CABIN HEATER

Log of Revisions				
Original 0				
Rev. No.	Log of Pgs.	Pgs. Rev.	Date	Approval
N/C 1	1-10	2 & 8	Mar 17, 1997	<i>[Signature]</i>
2	1-10	9 & 10	JUL 1 1 1997	<i>[Signature]</i>
FAA APPROVED: <i>[Signature]</i> Date: <u>3/29/96</u> Approved: <i>[Signature]</i> Ron May, Manager Denver Aircraft Certification Office, Northwest Mountain Region, Denver, Colorado				

FAA APPROVAL March 29, 1996
 REVISED: March 17, 1997
 REVISED: JUL 1 1 1997

**MODEL 407
FLIGHT MANUAL**

INTRODUCTION

The cabin heating system is a bleed air type which consists of bleed air plumbing, a heater control valve, and four heater ejectors. (as shown by figure 1) When the heater control valve is opened the bleed air flows from the engine compressor through the bleed lines to the ejectors, where it is mixed with cabin air and exhausted to both the front and rear passengers. Two of the ejectors are located under the front seats and two are located on the sides of the rear aft facing seats. For the front ejectors the warm air is ducted forward and through swivel outlets, which are located in the seat box structure. The aft ejectors are mounted on the sides of the aft cabin seat structure and warm air is ducted through the enclosures to the rear cabin area. The outlet flow can be individually adjusted by rotation of the swivel outlets or by rotating a flow control knob on the rear ejectors (opt-fwd and aft Flow control outlets). The heater control valve is mounted under the pilot's seat, and the heater control is located on the front of the seat box.

**MODEL 407
FLIGHT MANUAL**

INTRODUCTION (cont)

The system also features a defroster system. The system consists of an ON-OFF valve, located in the center console, and ejectors, located in each defroster diffuser. The ejectors pump warm air across the windshield. The original defroster blowers are not required but may remain installed at the option of the operator. The defroster and heater may be used simultaneously. Both the "heater" and "defroster" valves are infinitely adjustable from OFF to FULL ON, and may be set at the discretion of the operator.

A drain valve is also incorporated as a part of the heater system. This valve is used to drain cleaning solution overboard when washing the internal parts of the engine. The valve, which is located inside the RH engine access door, is automatic (closed by engine pressure).

An optional Chin Bubble Defroster System may also be installed. This system shares bleed air with the defroster, thus when the defroster is on, the chin bubble defroster is operating.

An optional Hi-Output (Arctic) heater system may be installed. This system provides 70% more performance than the standard heater.

MODEL 407
FLIGHT MANUAL

MODEL 407
FLIGHT MANUAL

BLEED AIR CABIN HEATER

SECTION 1 OPERATING LIMITATIONS

1. Limitations

1.1 Heater and Defroster Control shall be OFF during engine startup and shutdown.

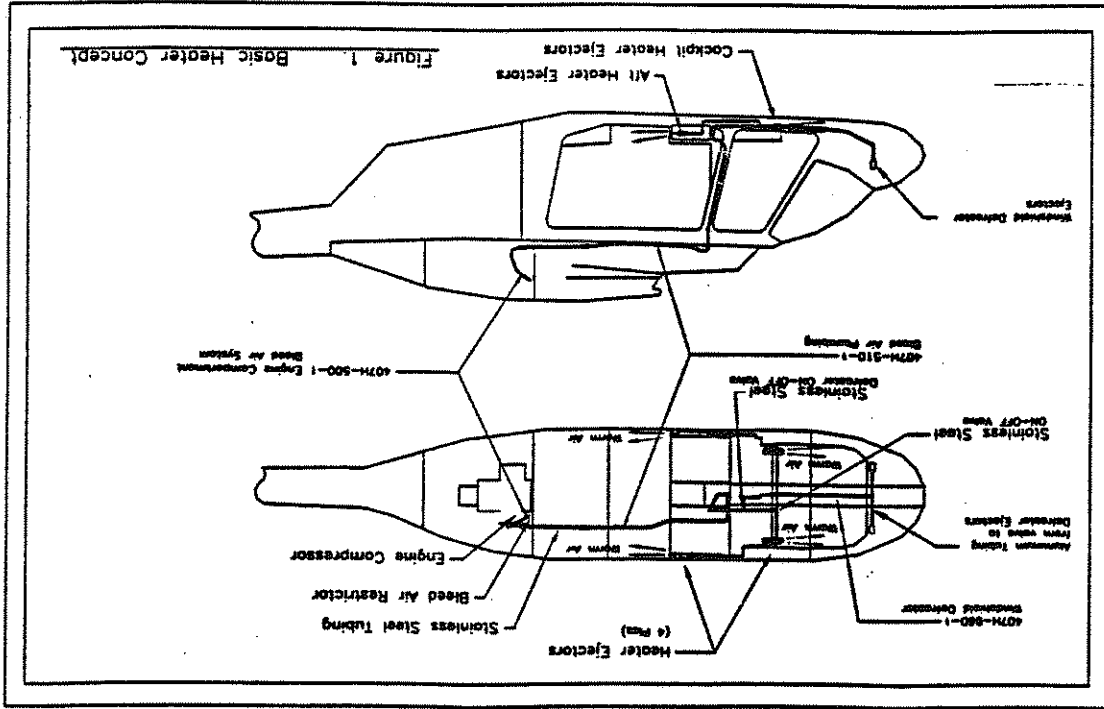

Figure 1. Basic Heater Concept.

MODEL 407
FLIGHT MANUAL

MODEL 407
FLIGHT MANUAL

BLEED AIR CABIN HEATER

BLEED AIR CABIN HEATER

SECTION 1 OPERATING LIMITATIONS

SECTION 1 OPERATING LIMITATIONS

1.1 PLACARDS AND MARKINGS

1.1 PLACARDS AND MARKINGS (cont)

Located on the front side of the RH seat support box..

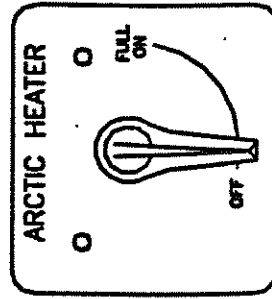
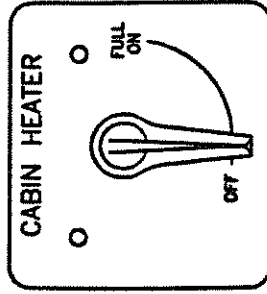

Located on the front side of the RH seat support box
(Optional Hi-Output heater)

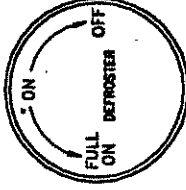

Located on the Defroster Control Knob.

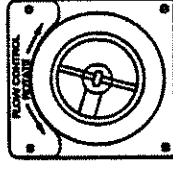

Located adjacent to the two forward air outlets.
(optional flow control feature)

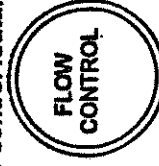

Located on the control knob at aft heater outlets
(optional flow control feature)

**MODEL 407
FLIGHT MANUAL**

Bleed Air Cabin Heater

Section 2 Normal Procedures

Engine Prestart Check

- Cabin heater valve - OFF
- Defroster Control knob - OFF

Before Takeoff

- Cabin heater valve - As desired
- Defroster Control knob - As desired

In Flight Operations

- Cabin heater valve - On as desired
- Defroster Control knob - As desired

Descent and Landing

- Cabin heater valve - As desired
- Defroster Control knob - As desired

**MODEL 407
FLIGHT MANUAL**

Bleed Air Cabin Heater

Section 3 Emergency Procedures

**Heater & Defroster Valves - OFF
for any of the following emergencies:**

- Engine Failure
- Engine Overtemperature
- Onboard Fire

Section 4 Malfunction Procedures

- No Change

Section 5 Performance Data

For operations involving Heater / Defroster only:

Refer to the basic Flight Manual FM-1 for take-off, hover, and landing data.

Subtract 55 fpm from the basic FM for Heater ON R/C performance.

For operations involving both the Heater / Defroster and the particle separator:

Refer to the Particle Separator Supplement FMS-3 for applicable performance data.

Page VI-1
407H-200M-2
Rev B

STC CERTIFICATE

United States of America
Department of Transportation—Federal Aviation Administration
Supplemental Type Certificate

Number SR00221DE

This certificate, issued to **Air Comm Corporation**

certifies that the change in the type design for the following product with the limitations and conditions therefor as specified hereon meets the airworthiness requirements of Part 27 of the Federal Aviation Regulations.

Original Product—Type Certificate Number: H2SW
Make: Bell Helicopter Textron, Inc.
Model: 407

Description of the Type Design Change:

Installation of an bleed air cabin heating system in accordance with Air Comm Corp. Master Drawing List DL-407H, Rev. A, dated February 14, 1996, or later FAA approved revision.

Limitations and Conditions:

1. Installation of STC SR00220DE is required.
2. FAA Approved Rotorcraft Flight Manual Supplement 407H-1, dated March 29, 1996 or later FAA approved revision is required for the 407H-200 and 407H-202 installation configurations.
3. FAA Approved Rotorcraft Flight Manual Supplement 407H-2, dated March 29, 1996 or later FAA approved revision is required for the 407H-201 and 407H-203 installation configurations.
4. Approval of this change in type design applies to the above model rotorcraft only. This approval should not be extended to aircraft of this model on which other previously approved modifications are incorporated unless it is determined that the interrelationship between this change and any of those other previously approved modifications, including changes in type design, will introduce no adverse effect upon the airworthiness of that rotorcraft.
5. A copy of this certificate must be maintained as part of the permanent records for the modified rotorcraft.

This certificate and the supporting data which is the basis for approval shall remain in effect until surrendered, suspended, revoked, or a termination date is otherwise established by the Administrator of the Federal Aviation Administration.

Date of application: July 8, 1995

Date reissued:

Date of issuance: March 29, 1996

Date amended: May 30, 1996



By direction of the Administrator

(Signature)
RONALD F. MAY Manager
Denver Aircraft Certification Office
Northwest Mountain Region, Denver, Colorado
(Title)

Any alteration of this certificate is punishable by a fine of not exceeding \$1,000, or imprisonment not exceeding 3 years, or both.

This certificate may be transferred in accordance with FAR 21.47.



Supplemental Type Approval

This approval is issued to:

Air Comm Corporation
Boulder Municipal Airport
3300 Airport Road
Boulder, CO 80301

Number: SH96-64

Issue No.: 1

Approval Date: August 2, 1996

Issue Date: August 2, 1996

Responsible Region:

Headquarters

Aircraft/Engine Type or Model:

Bell 407

Canadian Type Approval or Equivalent:

H-92

Description of Type Design Change:

Installation of a bleed air cabin heating system in accordance with FAA STC SR00221DE

Installation/Operating Data,
Required Equipment and Limitations:

Installation of a bleed air cabin heating system is to be done in accordance with Air Comm Corp. Master Drawing List DL-407H, Rev. A, dated February 14, 1996 or later approved revision.

Required Equipment

1. Installation of STA SH96-63 is required.
2. FAA Approved Rotorcraft Flight Supplement 407H-1, dated March 29, 1996 or later approved revision is required for the 407H-200 and 407H-202 installation configurations.
3. FAA Approved Rotorcraft Flight Supplement 407H-2, dated March 29, 1996 or later approved revision is required for the 407H-201 and 407H-203 installation configurations.

Conditions: This approval is only applicable to the type/model of aeronautical product specified therein. Prior to incorporating this modification, the installer shall establish that the interrelationship between this change and any other modification(s) incorporated will not adversely affect the airworthiness of the modified product.

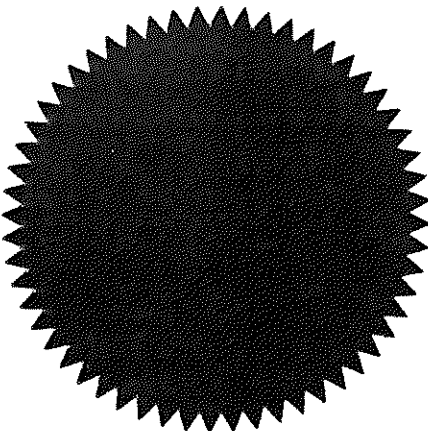

F. R. Davies

For Minister of Transport

Page VII-1
407H-200M-2
Rev B

Remove the following section
and retain with the
aircraft documents.

Air Comm Corporation
Boulder, CO 80301

INSTRUCTIONS FOR CONTINUED AIRWORTHINESS

for

BELL 407 CABIN HEATER, 407H-201/203

INTRODUCTION

This document provides maintenance and service information for the ACC 407H-201/203 cabin heater installations in the Bell 407 aircraft.

REFERENCE DOCUMENTS

1. Basic Bell Service Instructions.
2. AC43.13.1A, Acceptable Practices, Aircraft Alternation and Repair.
3. ACC Drawings:
 - 407H-201;Heater Installation. (Standard Heater)
 - 407H-203;Heater Installation. (Arctic Heater)
 - 407H-500;Engine Compartment Bleed Air Plumbing Installation.
 - 407H-518;Bleed Air Plumbing Installation - (Standard Heater).
 - 407H-522;Bleed Air Plumbing Installation - (Arctic Heater).
 - 407H-921;Heater Ejector Installation. (Standard Heater)
 - 407H-922;Heater Ejector Installation. (Arctic Heater)
 - 407H-960;Windshield Defroster Installation.
 - 407H-988;Chin Bubble Defog (optional).

SYSTEM DESCRIPTION AND OPERATION

The cabin heating system is a bleed air type which consists of bleed air plumbing, a bleed air valve, and four heater ejectors.

The bleed air flows from the engine compressor through the bleed lines to the ejectors, where it is mixed with cabin air and exhausted to both the front and rear passengers. The heater ejectors are located under the seats in the cockpit, and on the sides of the aft facing seats in the cabin. The warm air in the cockpit is ducted forward through swivel outlets which are located in the seat box structure. The warm air for the cabin is exhausted through heater shrouds located on each side of the aft facing cabin seats. The outlet flow can be individually adjusted by rotation of the swivel outlet in the front, or by rotating the flow control knob on the aft heater outlets (for flow control ejectors). This action controls the flow of bleed air from full ON to OFF.

The heater control valve is mounted under the pilot's seat, and the heater control is located on the front of the seat box.

The system also features a defroster system. The system consists of an ON-OFF valve, located in the center console, and ejectors, located in each defroster eyebrow. The ejectors pump warm air across the windshield. The original defroster blowers are not required but may remain installed at the option of the operator. The defroster and heater may be used simultaneously.

System Description and Operation (cont'd)

A bleed line drain valve is available as a part of the heater system. This valve is used to drain cleaning solution overboard when washing the internal parts of the engine.

Both the "heater" and "defroster" valves are infinitely adjustable from OFF to FULL ON, and may be set at the discretion of the operator. The drain valve is spring loaded open when the engine is not running and is closed due to engine pressure when the engine is operating.

MAINTENANCE INSTRUCTIONS

Conduct the following inspection functions at each annual inspection.

1. Inspect bleed air hose and tube assemblies for evidence of damage or deterioration. Replace if any of the above exists.
2. Inspect valve for mounting security.
3. Inspect valve for freedom of operation. This valve must be replaced if excessive friction exists.
4. Inspect bleed plumbing for insulation and security.
5. Verify security of control knobs and placards (see FMS for location).
6. Check the function of the automatic drain valve to insure that the valve is closed when the engine is operating. The valve should be checked with the heater "full ON." Slight leakage is permitted.
7. Visually inspect heater ejector nozzles for evidence of blockage, corrosion, deterioration, or deformation through the heater air outlet. No blockage of the heater ejector nozzles is allowable. If deterioration or deformation of the ejector nozzle is noted, contact the Air Comm Corporation Service Department for replacement part information. Check flow control valve for freedom of operation.

Maintenance Instructions (cont'd)

Spares List 407H-201-1 & -2 (407):

Item No.	Description	P/N	Qty/System
1	Restrictor	S-9216EC-8	1
2	Hose Assy	S-9276EC-5	1
3	Valve Assy-Drain	S-9230EC-1	1
4	Valve Assy-Heater Control (Std)	S-9268EC-3	1
5	Valve Assy-Heater Control	S-9268EC-1	1
6	Valve Assy-Defroster	S-9207EC-1	1
7	Knob	ES39300-1	1
8	Heater Placard (Valve On Off)	S-9701EC-30	1
9	Placard-Defroster Knob	S-9868-2	1
10	Label-Swivel Outlet ON-OFF	S-9722EC-3	2
11	Ejector Adapter	S-9704EC-1	2
12	O-Ring	AS3084-8	1
13	O-Ring	AS3084-10	1
14	Heater Placard (On off Arctic)	S-9701EC-33	1
15	Knob - Flow Control (Aft Htr)	ES39300-3	1
16	Placard - Aft Flow Control Knob	S-9701EC-26	1

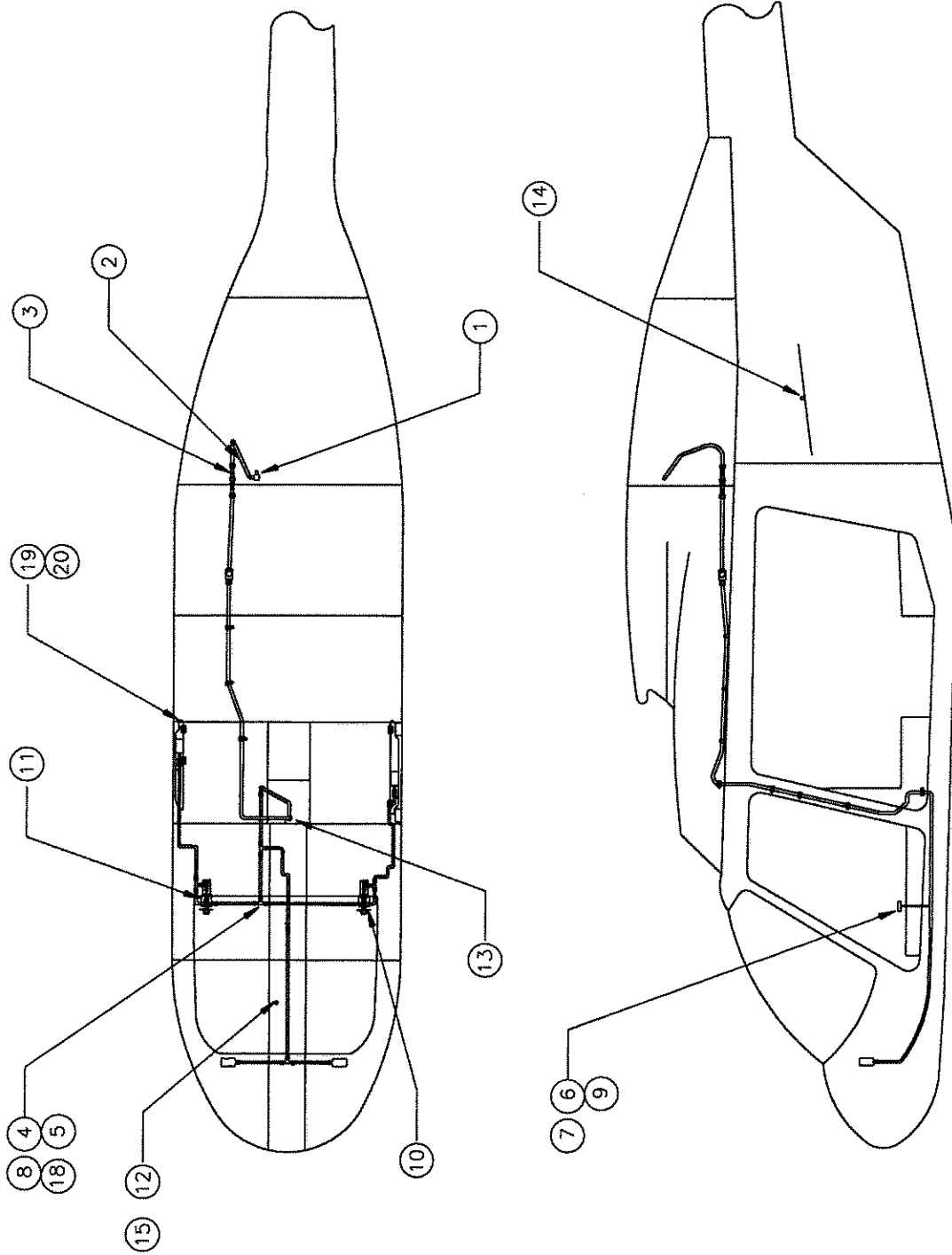

407H-201/203 Cabin Heater System (Std)

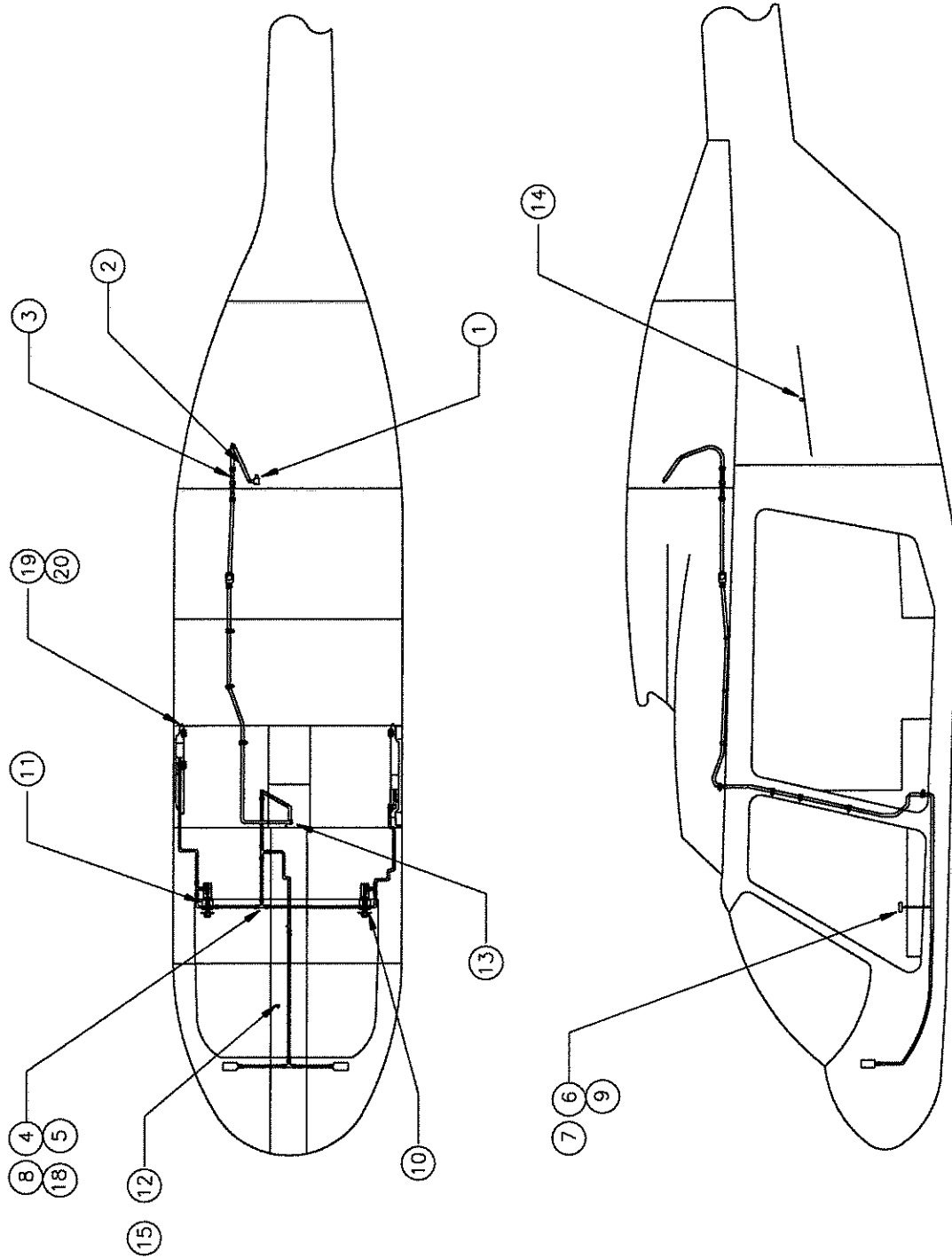

407H-201/203 Cabin Heater System
(Fwd & Aft Outlet Flow Control)
(Chin Bubble Defogger)

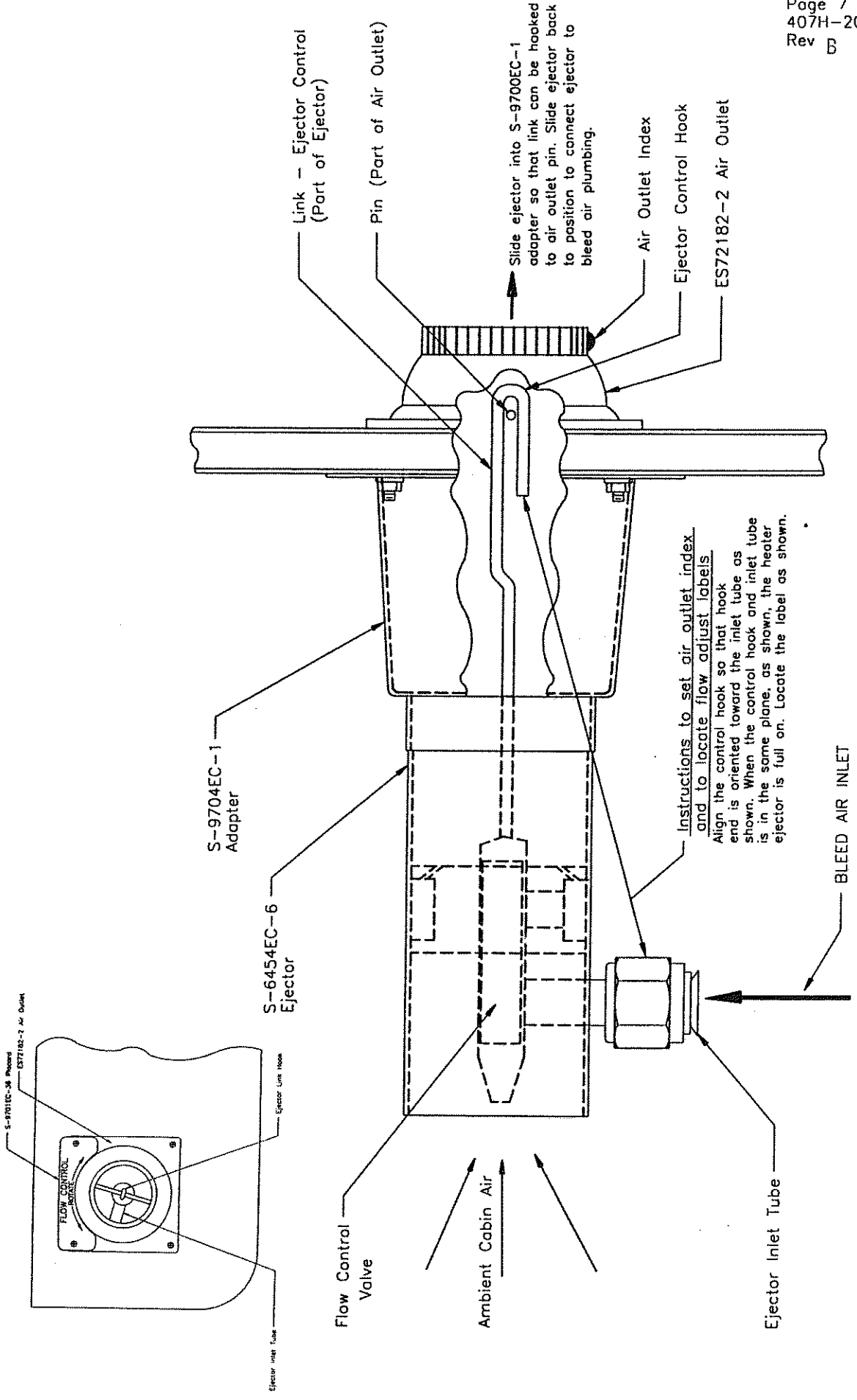

Heater Ejector Flow Control Indexing Procedure

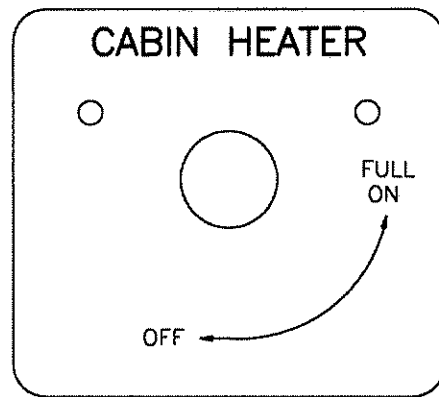

S-9701EC-21
Placard

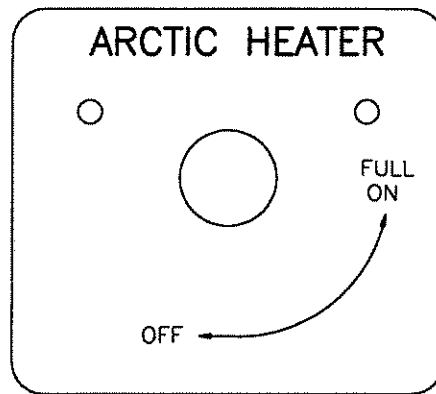

S-9701EC-33
Placard (Arctic Heater)

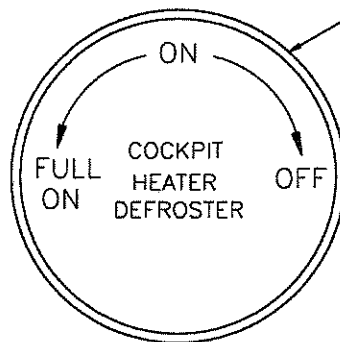

S-9868-2
Placard

Heater and Defroster Control Valve Placards

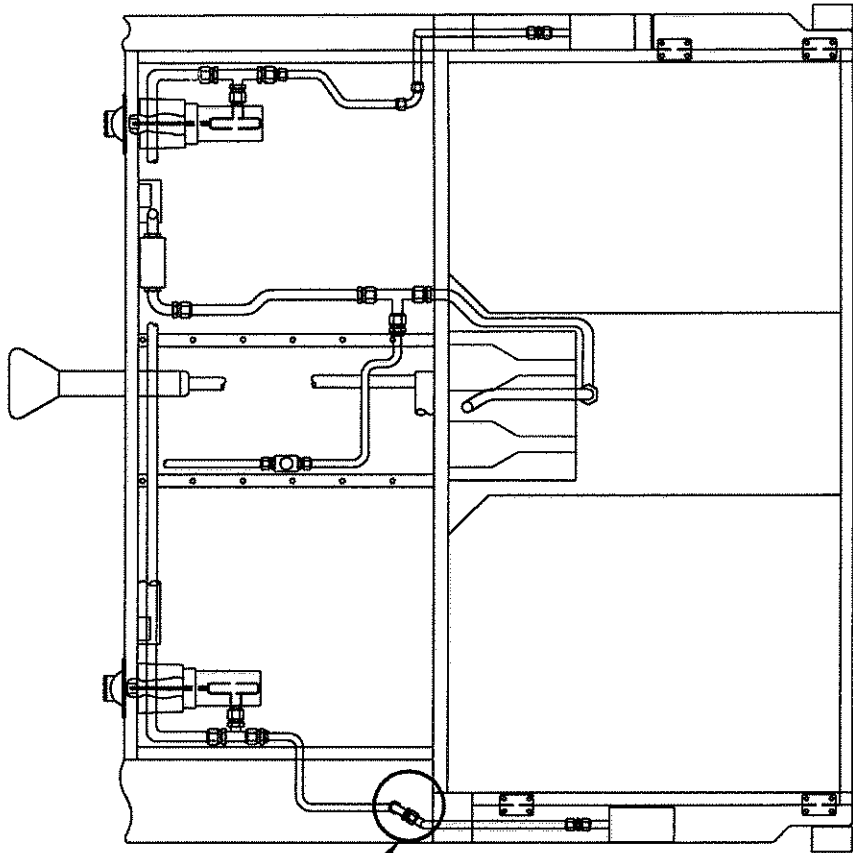

The throttle linkage hardware at this location must be arranged as shown below, to assure clearance with the heater bleed line

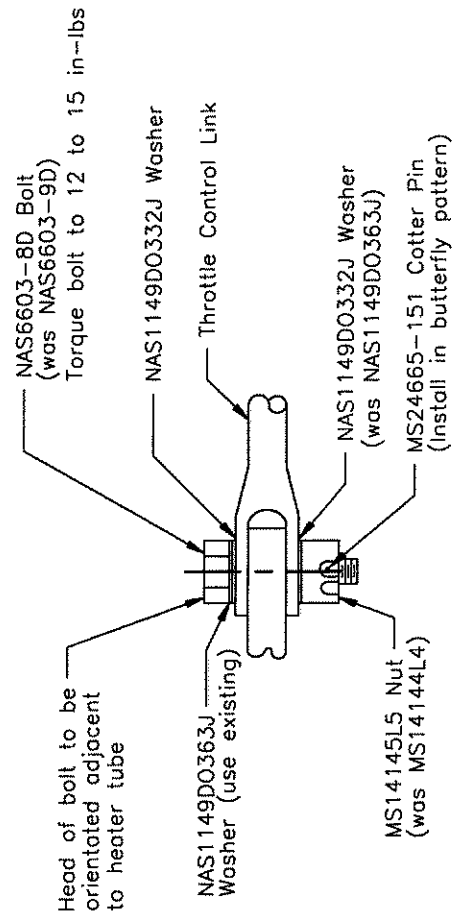

Required Throttle Linkage Hardware

WARRANTY

AIR COMM CORPORATION **Cabin Heating & Air Conditioning Systems**

Warranty Terms

Air Comm Corporation (hereafter referred to by ACC) warrants that products manufactured by ACC shall be free of defects in materials and workmanship for a period of one year from the date of installation and / or 1000 hours of flying time, which ever occurs first.

Limitations and Exclusions

Installation, maintenance and operation of the product must be in accordance with the specifications and instructions provided by ACC. The warranty registration must be returned to ACC within ten days of the date of installation.

This warranty shall not apply to any product repaired or altered by parties other than ACC unless express prior authorization is granted; nor shall this warranty apply to any product subjected to misuse or accident unless proof is submitted to the satisfaction of ACC that such misuse or accident was not a cause for the claimed defect.

The sole responsibility and liability of ACC and your exclusive remedy under any claim arising out of, connected with, or resulting from, this sale or the performance of breach of any condition of warranty thereunder, or from the manufacture, delivery, or use of the product shall be the repair or replacement of defective parts. Labor costs shall not be covered under any circumstances.

In no event, whether as a result of a breach of contract, warranty, tort (including negligence) or otherwise, shall ACC be liable for any special, consequential, incidental or penal damages or expenses including but not limited to loss of profit, goodwill, or revenues, loss of use of the equipment or any associated equipment, damage to associated equipment, cost of capital, cost of substitute products, facilities or services, down time, or cost or claims of third parties for such damages or expenses.

THE FOREGOING WARRANTY IS EXCLUSIVE AND IN LIEU OF ALL OTHER WARRANTIES OR REMEDIES WHETHER WRITTEN, ORAL, IMPLIED OR STATUTORY. ANY AND ALL IMPLIED WARRANTIES OR MERCHANTABILITY, FITNESS FOR A PARTICULAR PURPOSE, COURSE OF DEALING OR USAGE OF TRADE ARE HEREBY EXPRESSLY DISCLAIMED AND EXCLUDED.

Acceptance of the product by you shall constitute your acknowledgment and acceptance of the terms, provisions, limitations and exclusions set forth herein. Such terms, provisions, limitations and exclusions shall not be modified, deleted or supplemented except by an express written acknowledgment of ACC.

WARRANTEE PERFORMANCE: All claims under this warranty shall be made to ACC. All returned parts must be shipped prepaid for evaluation. Full details of the symptoms of the malfunction should be included to assist in the evaluation. Warranty credit or replacement will be extended only after ACC has determined that all conditions of this warranty have been met.

Air Comm Corporation
3300 Airport Road
Boulder, CO. 80301
Phone 303-440-4075
Fax 303-440-6355

Air Comm Corporation Malfunction Report

Submitted To:

Air Comm Corporation
3300 Airport Road
Boulder, CO. 80301
Attn: Service Manager
Phone No. 303-440-4075
Fax No. 303-440-6355

Date Reported or Claim Filled / /
Date Discrepancy Occurred / /

Submitted By: (Company Name, Address, Phone No.)

Submitted For: (Company Name, Address, Phone No.)

Phone Number _____

Phone Number _____

Fax Number _____

Fax Number _____

Person to contact _____

Person to contact _____

All warranty parts claims must be accompanied by the following information, failure to do so may delay the ability of ACC to determine the validity of the claim.

Aircraft Data: (Please complete all sections)

Model No.	Registration No.	Serial No.	Delivery Date	Total Hrs. at Delivery	Hrs. at Occurrence

Part Data: (Please complete all sections)

Quantity	Part Number	Part Name	Serial No. (if available)	Hrs. at Occurrence

Is this original equipment Yes No (if no, please complete these two blocks) ▶	Date Installed	Total A/C Hrs. when installed

Describe (in detail) of how the part failed, or reason for its return, (Please give any information that may be helpful in the evaluation of this part). _____

Warranty: Approved	Disapproved
------------------------------	-------------

WARRANTY

AIR COMM CORPORATION **Cabin Heating & Air Conditioning Systems**

Warranty Terms

Air Comm Corporation (hereafter referred to by ACC) warrants that products manufactured by ACC shall be free of defects in materials and workmanship for a period of one year from the date of installation and / or 1000 hours of flying time, which ever occurs first.

Limitations and Exclusions

Installation, maintenance and operation of the product must be in accordance with the specifications and instructions provided by ACC. The warranty registration must be returned to ACC within ten days of the date of installation.

This warranty shall not apply to any product repaired or altered by parties other than ACC unless express prior authorization is granted; nor shall this warranty apply to any product subjected to misuse or accident unless proof is submitted to the satisfaction of ACC that such misuse or accident was not a cause for the claimed defect.

The sole responsibility and liability of ACC and your exclusive remedy under any claim arising out of, connected with, or resulting from, this sale or the performance of breach of any condition of warranty thereunder, or from the manufacture, delivery, or use of the product shall be the repair or replacement of defective parts. Labor costs shall not be covered under any circumstances.

In no event, whether as a result of a breach of contract, warranty, tort (including negligence) or otherwise, shall ACC be liable for any special, consequential, incidental or penal damages or expenses including but not limited to loss of profit, goodwill, or revenues, loss of use of the equipment or any associated equipment, damage to associated equipment, cost of capital, cost of substitute products, facilities or services, down time, or cost or claims of third parties for such damages or expenses.

THE FOREGOING WARRANTY IS EXCLUSIVE AND IN LIEU OF ALL OTHER WARRANTIES OR REMEDIES WHETHER WRITTEN, ORAL, IMPLIED OR STATUTORY. ANY AND ALL IMPLIED WARRANTIES OR MERCHANTABILITY, FITNESS FOR A PARTICULAR PURPOSE, COURSE OF DEALING OR USAGE OF TRADE ARE HEREBY EXPRESSLY DISCLAIMED AND EXCLUDED.

Acceptance of the product by you shall constitute your acknowledgment and acceptance of the terms, provisions, limitations and exclusions set forth herein. Such terms, provisions, limitations and exclusions shall not be modified, deleted or supplemented except by an express written acknowledgment of ACC.

WARRANTEE PERFORMANCE: All claims under this warranty shall be made to ACC. All returned parts must be shipped prepaid for evaluation. Full details of the symptoms of the malfunction should be included to assist in the evaluation. Warranty credit or replacement will be extended only after ACC has determined that all conditions of this warranty have been met.

Air Comm Corporation
3300 Airport Road
Boulder, CO. 80301
Phone 303-440-4075
Fax 303-440-6355

WARRANTY REGISTRATION

_____	_____	_____
AIRCRAFT MODEL #	S/N	INSTALLER'S NAME
_____	_____	_____
AIRCRAFT REGISTRATION NUMBER		STREET
_____	_____	_____
PRODUCT P/N	CITY	ST ZIP
_____	_____	_____
DESCRIPTION		OWNER'S NAME
_____	_____	_____
DELIVERY DATE		STREET
_____	_____	_____
INSTALLATION DATE	CITY	ST ZIP
_____	_____	_____
TOTAL AIRCRAFT TIME		

OWNER'S SIGNATURE

TITLE (IF APPLICABLE)

DATE

⋮