

Service Letter

**TECHNICAL ASPECTS
FAA-DER APPROVED**

Service Letter: No. 322

Subject: Engine Bleed Port Gasket - Engine Compartment Bleed Air System.

Date: August 15, 1996

Applicability: Bell Model 407

Reference:

1. TC/S.T.A. SH96-63 and F.A.A. SR00220DE; Bell 407 Cabin Heater System.
2. Drawing # : 407H-500, Engine Compartment Bleed Air System.

Compliance: Optional - at the discretion of the operator.

It has come to our attention that the S-9702EC-1 gasket, shipped with a small number of subject systems (8 units), may not provide a positive seal under all conditions. This document provides authorization and instructions for the removal and replacement of this gasket. Replacement gaskets are available from Air Comm Customer Service Department, telephone 303-440-4075.

Removal and Replacement of S-9702EC-1 Gasket

Refer to figure 1. Remove retaining bolts from S-9702EC-2 fitting, and remove fitting and gasket. Replace with 23007167 gasket, install fitting and bolts and torque to specifications.

JUL 07 2004

Ans'd

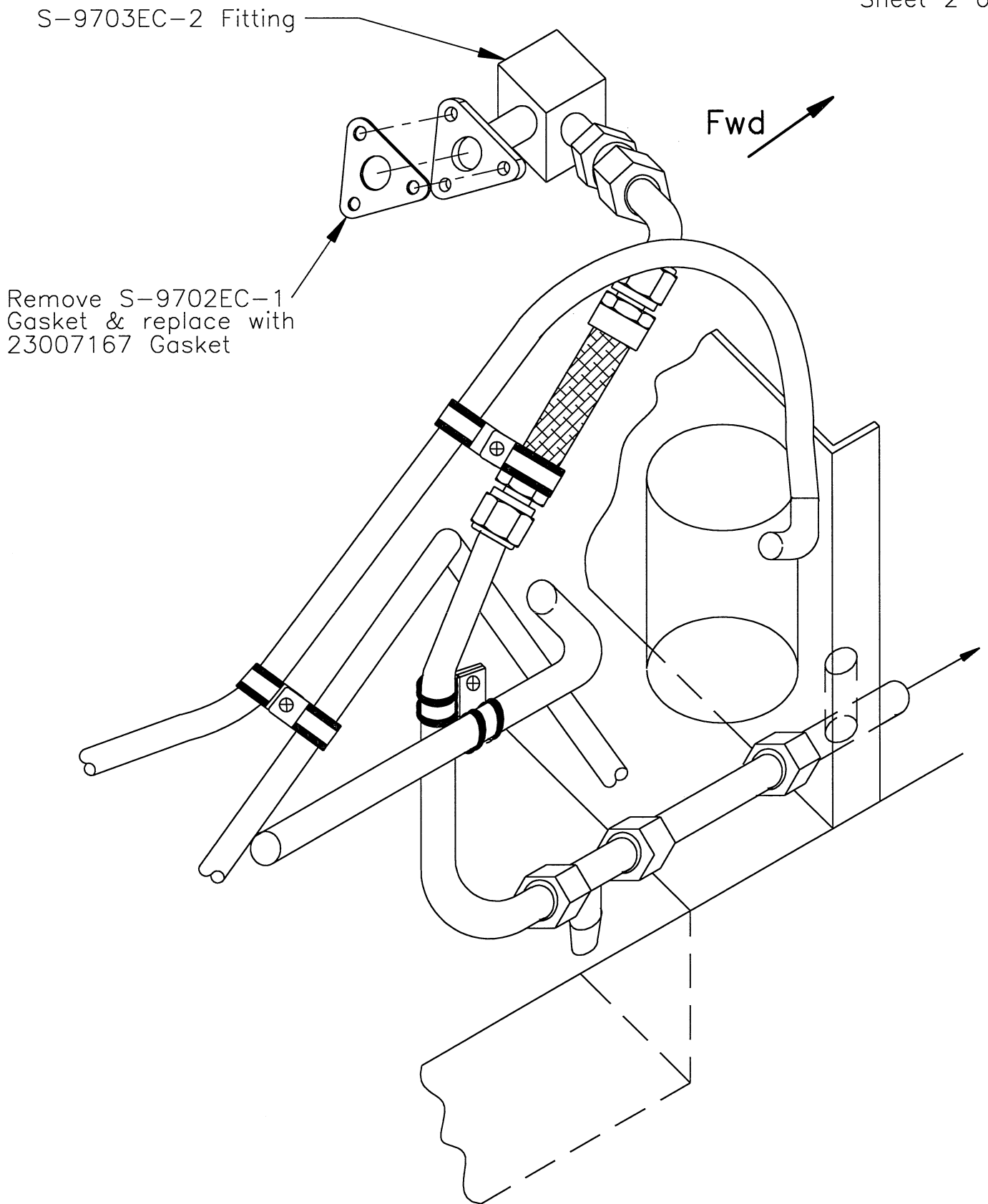

Figure 1: Engine Compartment
Bleed Air System

JUL 07 2004

Ans'd