



KEITH PRODUCTS, Inc.

Maintenance Manual
with
Illustrated Parts Catalog

Air-conditioning System for Cessna 172
Document No. CR-172-15
STC No. SA09457SC

<u>Section</u>	<u>Description</u>
21-50-00	Air-conditioning System
21-50-01	Electrical
21-50-02	Plumbing
21-50-03	Compressor
21-50-04	Condenser
21-50-05	Evaporator
21-50-06	Illustrated Parts Catalog

Prepared by: B. STUCKS

Checked by: M. A. KRAUSE

Approved by: M. J. REED

Approved by: T. DOELL

Original Date: July 29, 2002

Revision: E

Revision Date: October 14, 2009

RELEASE DATE

OCT 14 2009

Keith Products, Inc.
Maintenance Manual with Illustrated Parts Catalog
CR-172-15

RECORD OF REVISIONS

<u>REV</u>	<u>DATE</u>	<u>DESCRIPTION</u>	<u>BY</u>	<u>APPV</u>
NC	7/29/02	Initial Release	BCS	MAK
A	9/20/02	Added 21-50-06 to List of Effective Pages Reason: ER2000	RCG	MAK
B	6/1/06	Revised I/B's to section 21-50-06: Pg. 101 & added "Inactive after January 11, 2006." Added to section 21-50-06: Pg. 103 renumber I/N's 6-15, added I/N's 6, 13, 14, 15 & added "Use 172-0251-1 for spares replacement." Listed all pages #'s in section 21-50-06 to the List of Effective Pages & Table of Contents Revised section 21-50-01 page 2 <u>was</u> 172-0250 evaporator assembly <u>now</u> 172-0251-1 Added a page to List of Effective Pages Deleted a page from Table of Contents Added to section 21-50-06 page vii to IPC, Evaporator, Compressor, Condenser, Electrical, Plumbing Revised Table of Contents & Introduction page #'s Reason: Product Improvement per ER3084	CDW	MAK
C	3/14/07	Revised Section 21-50-06, I/N 6 on pg 403 <u>WAS</u> JBS75-7 <u>NOW</u> ES51000-1 Revised Section 21-50-06, I/N 15 on pg 505 <u>WAS</u> JBS6009-2 <u>NOW</u> JBS6009-9 Added pgs: 601-604 to Section 21-50-06 Reason: Drafting Error per ER3418	AJ	MAK
D	12/14/07	Added I/B's: 3, 4, 5, 6, 8, 10, 11, 15, 16, 20, 27, 28, 29, 30, 31, 32, 33, 34, 35, & 36 to pg 501 Added I/B's: 3, 4, 6, 23, 41, 44, 48, & 55 to pg 502 Added I/B's: 3, 4, 5, 6, 16, & 32 to pg 503 Added I/B's: 7, 9, 14, 24, 37, 39, 40, 41, 43, 44, 45, 48, 49, 50, 51, & 54 to pg 504 Added pages 505-507 and page 509 Added I/N's 20-41 to page 508 Edited I/N 2 <u>WAS</u> 172-0801-1 hose assembly Qty 1 Edited I/N 3 <u>WAS</u> 172-0802-1 hose assembly Qty 1 Edited I/N 4 <u>WAS</u> 172-0803-1 hose assembly Qty 1 Edited I/N 5 <u>WAS</u> 172-0804-1 hose assembly Qty 1 Edited I/N 6 <u>WAS</u> 172-0805-1 hose assembly Qty 1 Edited I/N 7 <u>WAS</u> 172-0806-1 hose assembly Qty 1 Reason: Drafting Error per ER3684	AJ	MAK

Keith Products, Inc.
 Maintenance Manual with Illustrated Parts Catalog
 CR-172-15

<u>REV</u>	<u>DATE</u>	<u>DESCRIPTION</u>	<u>BY</u>	<u>APPV</u>
E	10/14/09	Edited the following on Section 21-50-06. Edited callout on Page 101 <u>WAS</u> Inactive after January 11, 2006 <u>NOW</u> (172-0250-1 Configuration). Edited callout on Section 21-50-06 Page 102 <u>WAS</u> Effective after January 11, 2006 <u>NOW</u> (172-0251-1 Configuration). Deleted I/N 14 <u>WAS</u> ES61027-10 Motor on page 103. Deleted I/N 15 <u>WAS</u> 172-1251-1 Bracket on page 103. Added 172-0251-1 to I/N 2 on page 103. Added P/N's ES61060-2 and ES61027-10 to I/N 5 on page 103. Added P/N 172-1251-1 to I/N 6. Edited p/n on electrical schematic on Section 21-50- 1 page 2 <u>WAS</u> 172-0251-1 <u>NOW</u> 172-0250-1 and added alternate evaporator assy. electrical schematic. Reason: Reactivation of Previous Evaporator Conf. Per ER4079.	LEO	<i>TCW</i> <i>lase</i>
				RELEASE DATE
				OCT 14 2009

LIST OF EFFECTIVE PAGES

CHAPTER SECTION SUBJECT	PAGE	DATE
Title	i	Oct 14, 2009
List Of Revisions	ii	Dec 11, 2007
	iii	Oct 14, 2009
List of Service Bulletins	iv	Oct 14, 2009
List of Effective Pages	v	Oct 14, 2009
	vi	Oct 14, 2009
	vii	Oct 14, 2009
Table of Contents	viii	Oct 14, 2009
Introduction	ix	Oct 14, 2009
	x	Oct 14, 2009
21-50-00 A/C System, System Description	1	July 29, 2002
	2	July 29, 2002
	3	July 29, 2002
Troubleshooting	101	July 29, 2002
	102	July 29, 2002
	103	July 29, 2002
	104	July 29, 2002
	105	July 29, 2002
Maintenance Practices	201	July 29, 2002
	202	July 29, 2002
System Servicing	301	July 29, 2002
	302	July 29, 2002
	303	July 29, 2002
	304	July 29, 2002
Inspection	601	July 29, 2002
	602	July 29, 2002
	603	July 29, 2002

Keith Products, Inc.
 Maintenance Manual with Illustrated Parts Catalog
 CR-172-15

CHAPTER SECTION SUBJECT	PAGE	DATE
21-50-01 Electrical Description and Operation Troubleshooting	1	July 29, 2002
	2	Oct 14, 2009
	101	July 29, 2002
	102	July 29, 2002
	103	July 29, 2002
	104	July 29, 2002
	105	July 29, 2002
	106	July 29, 2002
21-50-02 Plumbing Description and Operation Maintenance Practices	1	July 29, 2002
	201	July 29, 2002
21-50-03 Compressor Description and Operation Maintenance Practices	1	July 29, 2002
	201	July 29, 2002
21-50-04 Condenser Description and Operation Maintenance Practices	1	July 29, 2002
	201	July 29, 2002
21-50-05 Evaporator Description and Operation Maintenance Practices	1	July 29, 2002
	201	July 29, 2002
21-50-06 Illustrated Parts Catalog	1	July 29, 2002
	101	Oct 14, 2009
	102	Oct 14, 2009
	103	March 17, 2006
	201	July 29, 2002
	202	July 29, 2002
	301	July 29, 2002
	302	July 29, 2002
	401	Oct 14, 2009
	402	July 29, 2002
	403	March 14, 2007
	501	Dec 11, 2007
	502	Dec 11, 2007
503	Dec 11, 2007	
504	Dec 11, 2007	

Keith Products, Inc.
Maintenance Manual with Illustrated Parts Catalog
CR-172-15

CHAPTER SECTION SUBJECT	PAGE	DATE
	505	Dec 11, 2007
	506	Dec 11, 2007
	507	Dec 11, 2007
	508	Dec 11, 2007
	509	Dec 11, 2007
	602	March 14, 2007
	603	March 14, 2007
	604	March 14, 2007

Keith Products, Inc.
 Maintenance Manual with Illustrated Parts Catalog
 CR-172-15
TABLE OF CONTENTS

<u>SUBJECT</u>	<u>SECTION</u>	<u>PAGE</u>
Introduction		ix
Air-conditioning System	21-50-00	
Description and Operation		1
Troubleshooting		101
Maintenance Practices		201
System Servicing		301
Inspection		601
Electrical	21-50-01	
Description and Operation		1
Troubleshooting		101
Plumbing	21-50-02	
Description and Operation		1
Maintenance Practices		201
Compressor	21-50-03	
Description and Operation		1
Maintenance Practices		201
Condenser	21-50-04	
Description and Operation		1
Maintenance Practices		201
Evaporator	21-50-05	
Description and Operation		1
Maintenance Practices		201
Illustrated Parts Catalog	21-50-06	1
Evaporator		101
Compressor		201
Condenser		301
Electrical		401
Plumbing		501
Cabin Air Duct		601
Exhaust / Intake		701

INTRODUCTION

1. PURPOSE

The purpose of this System Service Manual is to provide detailed instructions for the servicing, troubleshooting, checking and maintaining of the Cessna Model 172 with Keith Products, Inc. air-conditioning system. The System Service Manual supplements the Maintenance Manual supplied by Cessna for your particular aircraft.

2. SCOPE

The scope of the System Service Manual provides the maintenance technician with detailed information covering:

- Overall system level description and theory of operation.
- Component level description and theory of operation.
- System level checking and troubleshooting procedures.
- Procedures for servicing the air-conditioning system refrigerant.
- The identification of special equipment to accomplish the specific tasks.

Keith Products, Inc.
Maintenance Manual with Illustrated Parts Catalog
CR-172-15

3. GLOSSARY

Nonstandard abbreviations and symbols used in the Maintenance Manual are described below.

A/C	-	Air-conditioning
A/R	-	As Required
Assy	-	Assembly
Comm. Avail.	-	Commercially Available
Evap	-	Evaporator
Gnd	-	Ground
GPU	-	Ground Power Unit
SW	-	Switch
VDC	-	Volts Direct Current

AIR-CONDITIONING SYSTEM

SYSTEM DESCRIPTION

1. AIR-CONDITIONING SYSTEM DESCRIPTION

The Keith Products vapor cycle air-conditioning system uses liquid refrigerant R134a to cool the aircraft cabin. The major components for the R134a air-conditioning system consist of a compressor, condenser, receiver/drier, expansion valve, and evaporator. The starter ring-gear pulley turns the compressor via a belt. Figure 1 shows an operational schematic of the air-conditioning system.

The gas in the suction hose is pumped into the discharge hose and through the refrigerant system by the **compressor**. The compressor takes the low-temperature, low-pressure gas and compresses it to a high-temperature, high-pressure gas.

After the high-temperature, high-pressure gas leaves the compressor it enters the **condenser**. A 28 VDC blower forces air from the left hand side of the aircraft in the inlet duct and through the condenser. The air exits the condenser and leaves the condenser through the exhaust duct on the right hand side of the tailcone. This air cools the high-temperature, high-pressure gas as much as 100°F. The gas is cooled until it condenses to a medium-temperature, high-pressure liquid.





After the medium-temperature, high-pressure liquid leaves the condenser it enters the **receiver/drier**. The receiver/drier stores liquid refrigerant and filters any moisture out of the refrigerant.

After the medium-temperature, high-pressure liquid leaves the receiver/drier it enters the **expansion valve**. The expansion valve allows the medium-temperature, high-pressure liquid to expand to a low-temperature, low-pressure spray of liquid.

After the low-temperature, low-pressure spray of liquid leaves the expansion valve it enters the **evaporator**. A 28 VDC blower forces air from the cabin through the evaporator. Since the refrigerant in the evaporator can be as cold as 30°F, the air from the cockpit causes the low-temperature, low-pressure liquid spray to boil and then evaporate. This low-temperature, low-pressure gas passes through the suction hose into the compressor. The refrigerant cycle continues, cooling the aircraft cabin.

Air from the cabin is cooled as it passes through the evaporator and comes into contact with the refrigerant. Since the air is cooled, moisture from the air condenses in the evaporator and liquid water is formed. The water then drains overboard through the floor of the aircraft.

Keith Products, Inc.
Maintenance Manual with Illustrated Parts Catalog
CR-172-15

 HIGH PRESSURE GAS	 LOW PRESSURE GAS
 HIGH PRESSURE LIQUID	 LOW PRESSURE LIQUID

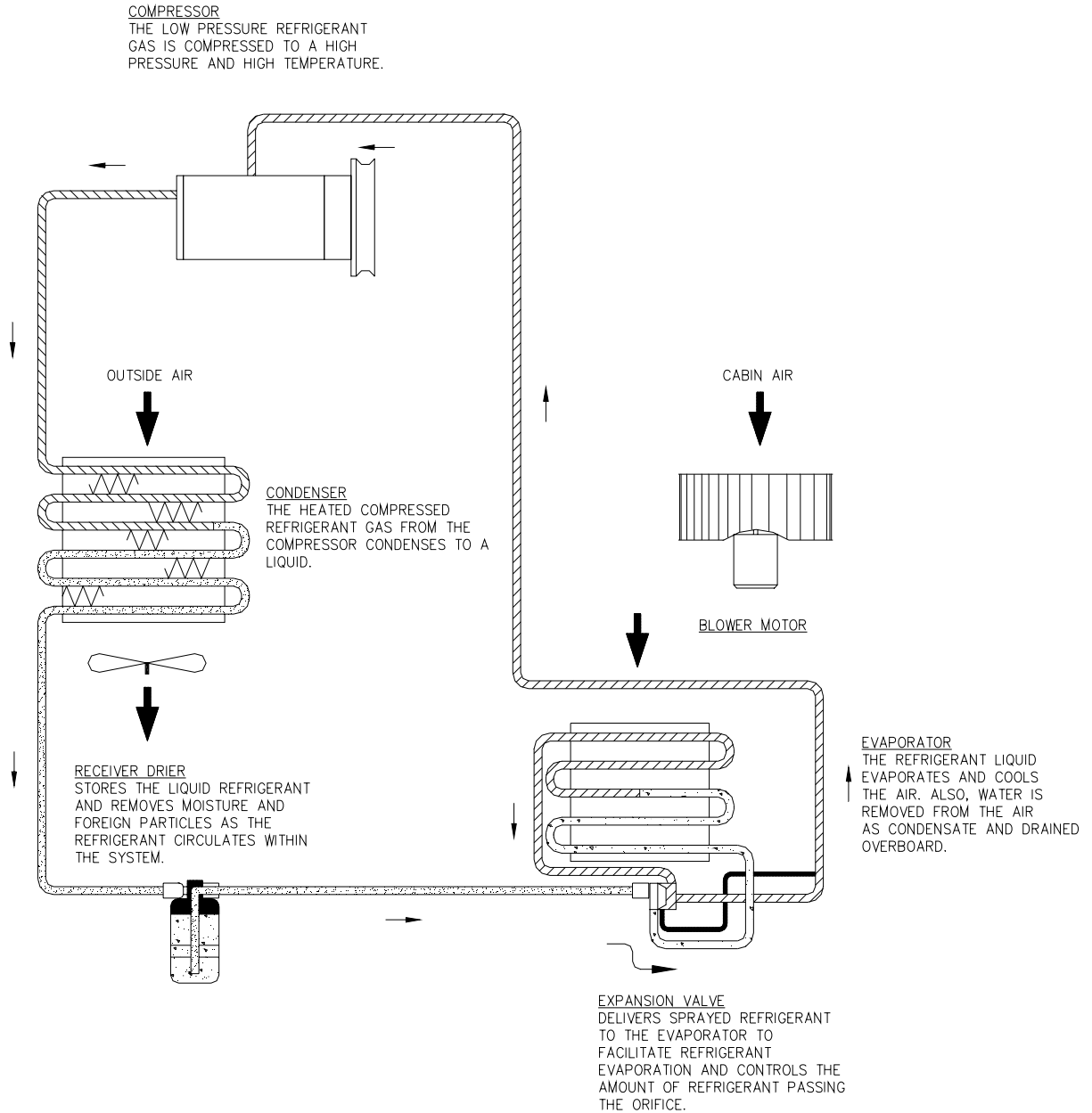
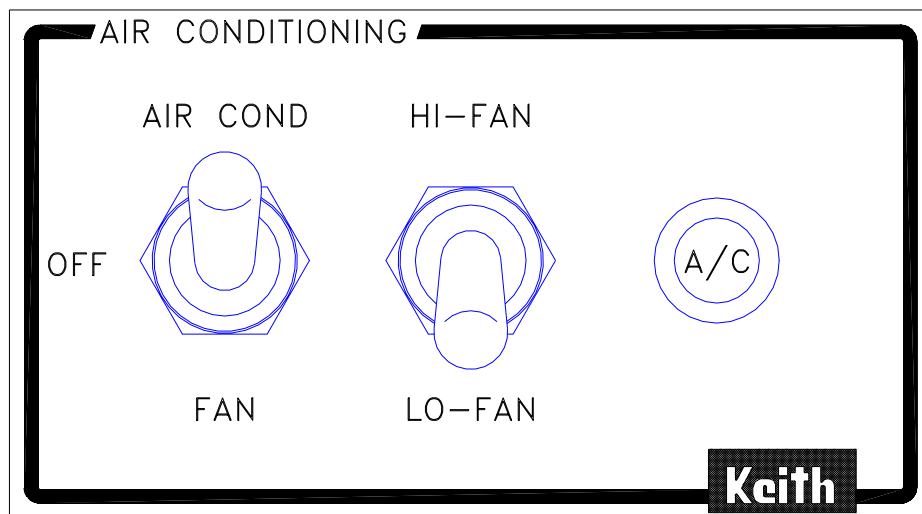

Figure 1. Air-conditioning Vapor Cycle System

2. SYSTEM OPERATION

The air-conditioning system is operated with the engine operating and power supplied to the aircraft electrical system. To operate the system proceed as follows:

- 1) Turn on air-conditioning system by placing left hand control switch in the AIR COND position.
- 2) For maximum cooling, place the FAN switch in the HI position, and close cabin and baggage doors.
- 3) Turn off air-conditioning system by placing left hand control switch in the OFF position.
- 4) Airflow may be varied by switching the FAN control switch between the LO and HI positions.
- 5) Cabin air may be re-circulated without the air-conditioning system operating by placing the left hand control switch in the FAN position.



AIR-CONDITIONING SYSTEM

TROUBLESHOOTING

1. GENERAL

The procedures below present troubleshooting charts for the air-conditioning system and the compressor. A diagnoses chart is presented for insufficient air-conditioning system cooling. The performance of the air-conditioning system varies with ambient temperature and humidity. The information below presents possible air-conditioning system problems and solutions.

CAUTION: Do not operate air-conditioning system with condenser air outlet blocked.

2. AIR-CONDITIONING SYSTEM DIAGNOSIS CHART

The following pages show a procedure for diagnosing air-conditioning system problems that will expedite the troubleshooting process.

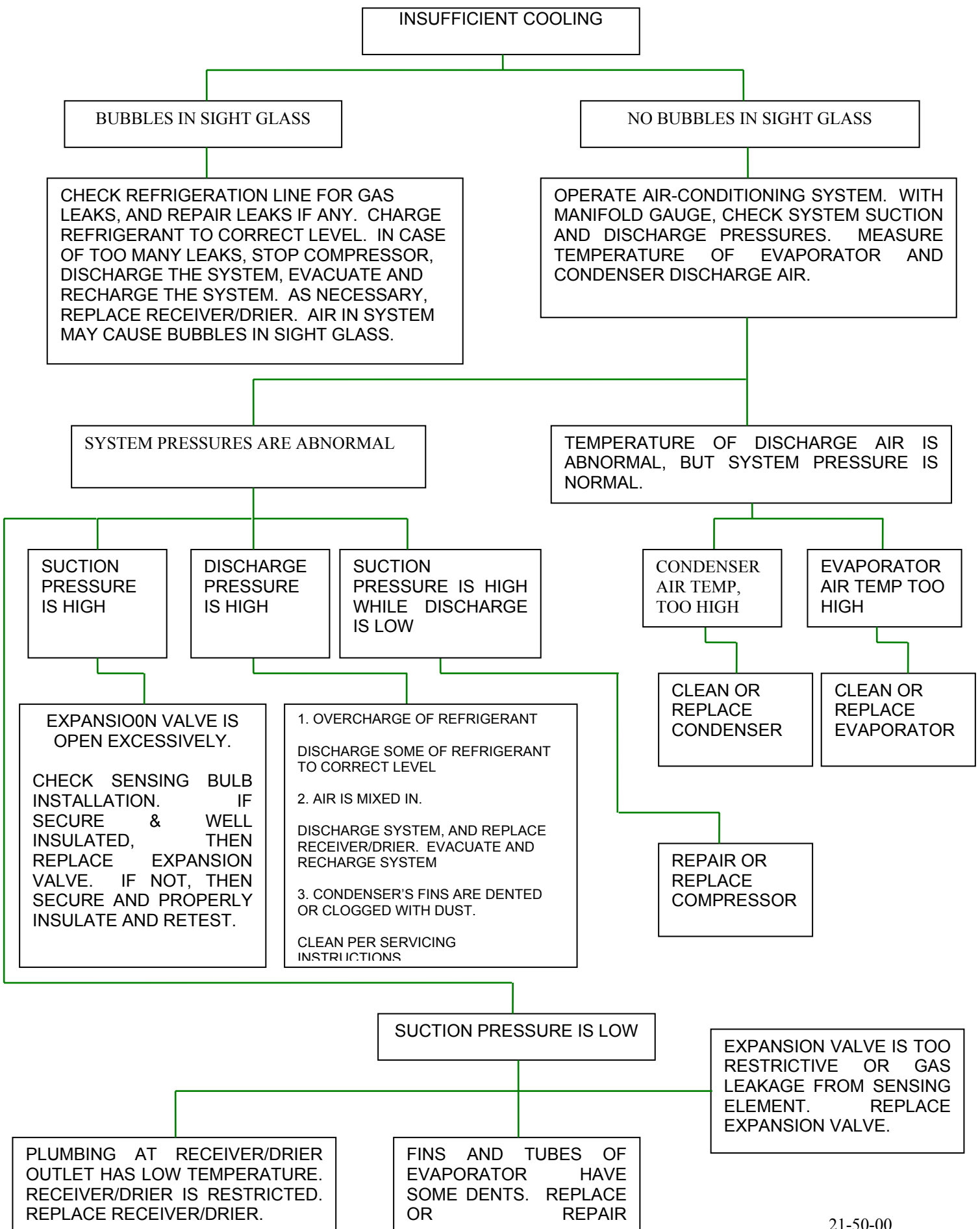

FIGURE 2: AIR-CONDITIONING SYSTEM DIAGNOSIS CHART

3. AIR-CONDITIONING SYSTEM TROUBLESHOOTING

CONDITION	SERVICE PRESSURE GAUGE READING	PROBABLE CAUSE	CORRECTIVE ACTION
<p>INSUFFICIENT REFRIGERANT CHARGE</p> <p>Insufficient cooling. Bubbles appear in sight glass.</p>	<p>SUCTION PRESSURE: below normal</p> <p>DISCHARGE PRESSURE: below normal</p>	<p>Refrigerant is low, or leaking a little.</p>	<p>1. Leak test. 2. Repair leak. 3. Charge system.</p> <p>Evacuate as necessary and recharge system.</p>
<p>ALMOST NO REFRIGERANT</p> <p>No cooling action. A lot of bubbles or something like mist appears in sight glass.</p>	<p>SUCTION PRESSURE: much below normal</p> <p>DISCHARGE PRESSURE: much below normal</p>	<p>Serious refrigerant leak.</p>	<p>Stop compressor immediately.</p> <p>1. Leak test. 2. Discharge system. 3. Repair Leak(s). 4. Replace receiver/drier, if necessary. 5. Check oil level. 6. Evacuate and recharge system.</p>
<p>FAULTY EXPANSION VALVE</p> <p>a) Slight cooling. Sweating or frosted expansion valve outlet.</p> <p>b) Insufficient cooling. Sweated suction line.</p> <p>c) No cooling. Sweating or frosted suction line.</p>	<p>a) SUCTION PRESSURE: below normal</p> <p>DISCHARGE PRESSURE: below normal</p> <p>b) SUCTION PRESSURE: above normal</p> <p>DISCHARGE PRESSURE: above normal</p> <p>c) SUCTION PRESSURE: above normal</p> <p>DISCHARGE PRESSURE: below normal</p>	<p>a)Expansion valve restricts refrigerant. Or, expansion valve is clogged. Or, expansion valve is inoperative. Or, valve stuck closed. Thermal bulb has lost charge.</p> <p>b)Expansion valve allows too much refrigerant through evaporator.</p> <p>Sensing bulb on suction line not well insulated or properly attached to line.</p> <p>c)Faulty expansion valve.</p>	<p>a) Replace expansion valve.</p> <p>b)</p> <p>1. Check valve for operation. If suction side does not show a pressure decrease, replace valve. 2. Check security and insulation on sensing bulb.</p> <p>c)</p> <p>1. Discharge system. 2. Replace valve. 3. Evacuate and replace system.</p>

Keith Products, Inc.
 Maintenance Manual with Illustrated Parts Catalog
 CR-172-15

CONDITION	SERVICE PRESSURE GAUGE READING	PROBABLE CAUSE	CORRECTIVE ACTION
<p>AIR IN SYSTEM</p> <p>Insufficient cooling.</p> <p>Sight glass shows occasional bubbles.</p>	<p>SUCTION PRESSURE: above normal</p> <p>DISCHARGE PRESSURE: above normal</p>	<p>Air mixed with refrigerant in system.</p>	<ol style="list-style-type: none"> 1. Discharge system. 2. Replace receiver/drier. 3. Evacuate and charge system.
<p>MOISTURE IN SYSTEM</p> <p>After operation for a while, pressure on suction side may show vacuum pressure reading. During this condition, discharge air will be warm. As warning of this, reading shows approx. 6 psi oscillation.</p>	<p>SUCTION PRESSURE: below normal</p> <p>DISCHARGE PRESSURE: above normal</p>	<p>Drier is saturated with moisture. Moisture has frozen at expansion valve. Refrigerant flow is restricted.</p>	<ol style="list-style-type: none"> 1. Discharge system. 2. Replace receiver/ drier (twice if necessary). 3. Evacuate system completely. (Repeat 30 minute evacuating three times.) 4. Recharge system.
<p>FAULTY CONDENSER</p> <p>Insufficient cooling.</p> <p>Bubbles appear in sight glass of drier.</p> <p>Suction line is very hot.</p>	<p>SUCTION PRESSURE: above normal</p> <p>DISCHARGE PRESSURE: above normal</p>	<p>Condenser air or refrigerant flow is restricted.</p>	<p>Check condenser for dirt accumulation or bent fins. Clean/ replace as necessary.</p> <p>Check for refrigerant overcharge.</p> <p>If pressure remains high in spite of all above actions taken, remove and inspect the condenser for possible oil clogging.</p>
<p>HIGH PRESSURE LINE BLOCKED</p> <p>Insufficient cooling.</p> <p>Frosted high pressure liquid line.</p>	<p>SUCTION PRESSURE: much below normal</p> <p>DISCHARGE PRESSURE: much above normal</p>	<p>Drier clogged, or restriction in high pressure line.</p>	<ol style="list-style-type: none"> 1. Discharge system. 2. Replace receiver/drier. 3. Evacuate and charge system

Keith Products, Inc.
 Maintenance Manual with Illustrated Parts Catalog
 CR-172-15

CONDITION	SERVICE PRESSURE GAUGE READING	PROBABLE CAUSE	CORRECTIVE ACTION
<p>FAULTY COMPRESSOR</p> <p>a) Insufficient cooling.</p> <p>b) Insufficient cooling.</p> <p>c) Rough running.</p>	<p>a) SUCTION PRESSURE: much below normal</p> <p>DISCHARGE PRESSURE: much below normal</p> <p>b) SUCTION PRESSURE: much above normal</p> <p>DISCHARGE PRESSURE: much below normal</p>	<p>a) Internal problem in compressor, or damaged gasket and valve.</p> <p>b) Internal problem with compressor body.</p> <p>c) Internal problem with compressor body.</p>	<ol style="list-style-type: none"> 1. Discharge system. 2. Remove and check compressor. 3. Repair or replace compressor. 4. Check oil level. 5. Replace receiver/drier. 6. Evacuate and charge system.
<p>TOO MUCH OIL IN SYSTEM (Excessive)</p> <p>Insufficient cooling.</p>	<p>SUCTION PRESSURE: above normal</p> <p>DISCHARGE PRESSURE: above normal</p>	<p>Too much oil circulates with refrigerant, causing the cooling capacity of the system to be reduced.</p>	<p>Refer to Oil Level Check for correcting oil level.</p>
<p>WATER BEING BLOWN OUT OF EVAPORATOR</p>	<p>SUCTION PRESSURE: normal</p> <p>DISCHARGE PRESSURE: normal</p>	<p>Blocked evaporator drain.</p>	<p>Check evaporator drain for downhill routing and repair any kinks or blockage in drain tubing.</p>

AIR-CONDITIONING SYSTEM

MAINTENANCE PROCEDURES

A. General

The following procedures are used to perform typical maintenance on the air-conditioning system plumbing. Procedures are provided for making connections to components, and replacing the expansion valve. Keith Products air-conditioning systems use swaged hose fittings with "o-ring" type connections.

B. Tools and Equipment

Designation	Ref. No.	Qty	Remarks
Polyolester Oil	Comm. Avail.	A/R	Viscosity ISO 68
Sealant	ES49000-1	A/R	None

C. Connection to Components - O-Ring Replacement

1. Place the appropriate o-ring over the tube "O" end of the fitting.
 2. Lubricate o-ring with polyolester oil viscosity ISO 68 or ES49000-1 sealant prior to assembly.
 3. Apply sealant to all fitting-mating surfaces prior to assembly.

D. Expansion Valve Removal and Installation

The following procedure is used to remove or install the air-conditioning system expansion valve, located on the inlet side of the evaporator coil.

1. Discharge system in accordance with instructions included in this manual.
2. Disconnect and cap the liquid hose from the expansion valve inlet.
3. Remove the insulation covering the thermal sense bulb on the suction tubing.
4. Cut the tie wraps binding the sense bulb to the suction tubing.
5. Disconnect the fitting that connects the expansion valve to the coil, and remove the expansion valve.
6. Discard the old expansion valve and o-ring.
7. Install new ES26104-1 expansion valve and ES49011-2 o-ring.
8. Lubricate o-ring with polyolester oil viscosity grade ISO 68 or apply ES49000-1 sealant to fitting mating surfaces prior to assembly.
9. Install the thermal sense bulb such that it makes contact with the suction tube along its entire length with two or more cable ties as shown in Figure 3.
10. Insulate the bulb thoroughly with insulation to suction tubing.

NOTE: Always utilize two wrenches as not to twist or bend the soft copper lines.

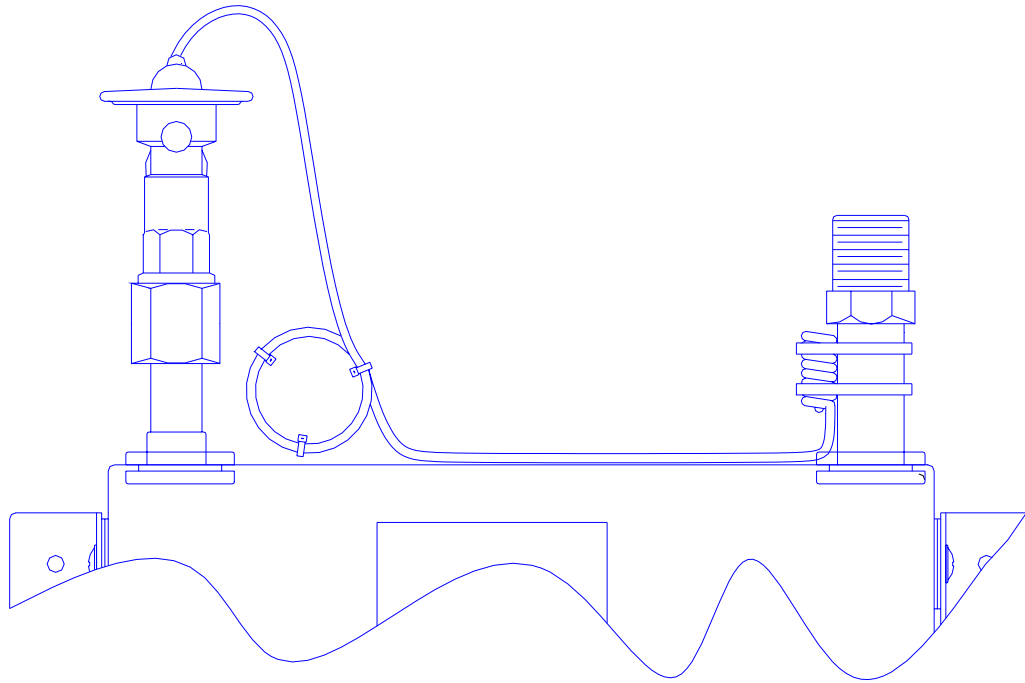

Figure 3
Correct expansion valve and sense bulb orientation

AIR-CONDITIONING SYSTEM

SYSTEM SERVICING

1. GENERAL

The air-conditioning system uses refrigerant R134a and the compressor lubricating oil used is Polyolester Oil viscosity grade (ISO) 68. No other refrigerant or compressor oil should be used.

Refrigerant R134a is non-explosive, non-flammable, non-corrosive, has practically no odor, and is heavier than air. Although R134a is classified as a safe refrigerant, certain precautions must be observed to personnel and property when working with R134a refrigerant.

WARNING:

- A. Liquid R134a, at normal atmospheric pressure and temperature, evaporates so quickly that it tends to freeze anything that it contacts. Care must be taken to prevent any liquid refrigerant from coming into contact with skin.
- B. Always wear safety goggles when servicing any part of the refrigerant system to prevent refrigerant from coming into contact with the eyes.
- C. The refrigerant containers and the air-conditioning components are under pressure. Do not expose the air-conditioning system or refrigerant containers to heat. Do not puncture the air-conditioning components or the refrigerant containers.

CAUTION: Do not operate air-conditioning system with condenser air outlet blocked.

2. DISCHARGING SYSTEM

A. General

The air-conditioning system refrigerant must be discharged prior to disconnecting or removing any components in the refrigerant loop. Federal law prohibits discharging refrigerant into the atmosphere. Use only an R134a compatible recycling/recovery unit when discharging the air-conditioning system.

B. Tools and Equipment

Designation	Ref. No.	Qty	Remarks
R134a Compatible Recycling/Recovery Unit	Comm. Avail.	1	None

C. Discharging Procedure

- 1) Connect R134a compatible recycling/recovery unit to the R134a service valves located near the evaporator installation on the right hand side of the aircraft.
- 2) Empty the recycling/recovery unit of oil.
- 3) Discharge the air-conditioning system in accordance with the recovery unit's instructions.
- 4) Empty the oil from the recycling/recovery unit. Note the amount of oil removed during the system discharge. This amount of oil must be added to the air-conditioning system prior to charging. Only use polyolester oil viscosity grade ISO 68.

3. EVACUATING SYSTEM

A. General

The air-conditioning system must be evacuated prior to charging the system with refrigerant. Evacuating the system removes any moisture and air that may be in the system. Use only an R134a compatible recycling/recovery unit when evacuating the air-conditioning system.

B. Tools and Equipment

Designation	Ref. No.	Qty	Remarks
R134a Compatible Recycling/Recovery Unit	Comm. Avail.	1	None

C. Evacuating Procedure

- 1) Connect R134a compatible recycling/recovery unit to the R134a service valves on the aircraft's air-conditioning system.
- 2) Empty the oil from the recycling/recovery unit.
- 3) Evacuate the air-conditioning system in accordance with the recovery unit's instructions for a minimum of 15 minutes.
- 4) Empty the oil from the recycling/recovery unit. Note the amount of oil removed during the vacuum. This amount of oil must be added to the air-conditioning system prior to charging. Only use polyolester oil viscosity grade ISO 68.
- 5) Once the air-conditioning system has been evacuated, it is then ready for charging with new/recycled R134a refrigerant.

4. CHARGING SYSTEM

A. General

Use only R134a refrigerant when charging air-conditioning system. Federal law prohibits discharging refrigerant into the atmosphere. Use only R134a compatible recycling/recovery unit when charging the air-conditioning system.

B. Tools and Equipment

Designation	Ref. No.	Qty	Remarks
R134a Compatible Recycling/Recovery Unit	Comm. Avail.	1	None
R134a refrigerant	Comm. Avail	2.5 lbs.	None
Polyolester Oil	Comm. Avail	5 fl. oz.	Viscosity ISO 68

C. Charging Procedure

- 1) Connect R134a compatible recycling/recovery unit to the R134a service valves on the aircraft's air-conditioning system. If recovery unit does not have pressure gauges, connect service pressure gauges to air-conditioning system.
- 2) Evacuate the air-conditioning system for 15 minutes in accordance with the instructions in this report.
- 3) Close the low side and open the high side on the recycling/recovery unit.
- 4) Add polyolester oil viscosity ISO 68 to the high side service tee using the refrigerant recycling/recovery unit while the system is under a vacuum.

NOTE: Adding refrigerant or oil from the recycling/recovery unit directly to the low-pressure service tee will allow liquid refrigerant or oil to enter the compressor.

The compressor is only designed to compress gas refrigerant, and liquid refrigerant or oil may damage/destroy the compressor. Always close the low side of the recycling/recovery unit during charging.

- 5) Charge the air-conditioning system in accordance with the recovery unit's instructions except as noted.
- 6) If bubbles are present at the sight glass after the system has been running for a minimum of 5 minutes, add refrigerant as necessary.

AIR-CONDITIONING SYSTEM

INSPECTION/CHECKS

1. GENERAL

General service procedures are provided to keep the air-conditioning system operating at peak efficiency. Procedures are provided for inspection intervals, refrigerant charge inspection, refrigerant leak inspection, and compressor oil level inspection.

CAUTION: Do not operate air-conditioning system with condenser air outlet blocked.

A. Tools and Equipment

Designation	Ref. No.	Qty	Remarks
Service Pressure Gage	Comm. Avail.	1	None
Electronic Leak Detector	Comm. Avail.	A/R	Type H-10G
Polyolester Oil	Comm. Avail.	A/R	Viscosity ISO 68

2. INSPECTION INTERVALS

A. General

Periodic inspections of the air-conditioning system will keep the system operating at peak efficiency. The inspections are simple visual inspections requiring a minimal amount of time.

B. Inspection Intervals

ITEM	INSPECT FOR	INTERVAL	ACTION
AIR-CONDITIONING SYSTEM COMPONENTS	DIRT, DAMAGE	EVERY 600 HOURS*	CLEAN OR REPLACE COMPONENTS AS NECESSARY
COMPRESSOR BELT	TENSION, WEAR	WITHIN 5 HOURS OF INSTALLING A NEW BELT, THEN EVERY 600 HOURS*	TENSION OR REPLACE AS NECESSARY
SIGHT GLASS	PROPER REFRIGERANT LEVEL	WHEN PROBLEM IS SUSPECTED*	DISCHARGE/CHARGE AS NECESSARY
EVAPORATOR AND CONDENSER COILS	DIRT	EVERY 600 HOURS*	CLEAN OR REPLACE AS NECESSARY

*Or every annual inspection, which ever comes first.

3. REFRIGERANT LEVEL INSPECTION

To be performed when improper refrigerant charge is suspected.

- A. Select air-conditioning system switch to AIR COND position.
- B. Set the fan speed switch to the HI position.
- C. Run system for five (5) minutes minimum.
- D. Check that the receiver/drier inlet and outlet fitting temperatures are the same. If the outlet is considerably colder, the receiver/drier screen may be clogged and may need replacement.
- E. Check the sight glass for bubbles. No bubbles should be visible after 5 minutes of operation.
NOTE: The refrigerant bubbles are more difficult to see at ambient temperatures below 65°F. Always re-check refrigerant level when ambient temperature is above 65°F for proper level.
- F. Add/Remove refrigerant as necessary.

4. REFRIGERANT SYSTEM LEAKAGE INSPECTION

To be performed when refrigerant leak is suspected.

- A. The system leakage check is to be performed in an area with an ambient temperature of 65°F or above.
- B. Install service pressure gage to low and high pressure R134a service valves.
- C. On systems that have not been operated for 2 weeks or longer, operate the system for a minimum of 15 minutes. This will lubricate the compressor shaft seal and ensure a more accurate leakage check of the shaft seal.
- D. With the system off, and using a type H-10G electronic leak detector or equivalent, check all connections, compressor shaft seal, and fabricated components for leakage. No leakage is acceptable.

5. COMPRESSOR OIL LEVEL CHECK

NOTE: It is not necessary to check the compressor oil level during routine maintenance. It only needs to be checked when a system component is replaced or when incorrect oil level is suspected. Only polyolester oil viscosity grade ISO 68 should be used.

1. Operate air-conditioning system for 10 minutes. This will collect as much oil as possible in the compressor.
2. Discharge air-conditioning system in accordance with the discharging instructions in this manual.
3. Remove either discharge or suction port hose fitting.
4. Remove oil drain plug and allow all oil to drain.
5. Add 5 ounces of oil to the compressor.
6. Clean oil drain area and install drain plug. Torque to 6 - 9 ft-lbs.
7. Install hose fitting.

8. Charge air-conditioning system in accordance with the charging instructions in this manual.

ELECTRICAL

DESCRIPTION AND OPERATION

1. GENERAL

The electrical system of the Cessna 172 air-conditioning system operates from the main 28 VDC buss. The major components of the electrical system are:

Evaporator Blower: Blows cold air into the cabin.

Condenser Blower: Removes heat from the refrigerant

Compressor Clutch: Engages/disengages the compressor

2. SAFETY FEATURES

During certain flight configurations the compressor clutch and condenser blower are disabled to supply electrical power to more critical systems. Depending on the aircraft model and type, automatic load shedding removes power to the compressor clutch and condenser blower when high load systems are engaged. The evaporator blower will remain available to re-circulate cockpit air during all flight configurations.

Before electrical current reaches the compressor clutch it passes through the JBS2020-5 Pressure Switch and the JBS60-2 Freeze Switch. In the event of excessive refrigerant pressure during flight (caused by failed or blocked condenser blower) or inadequate refrigerant pressure (caused by a leak in the plumbing) the JBS2020-5 pressure switch will open and disable the compressor clutch. In the event of extremely low temperature air exiting the evaporator (which may cause the coil to freeze) the JBS60-2 Freeze Switch will open and disable the compressor clutch.

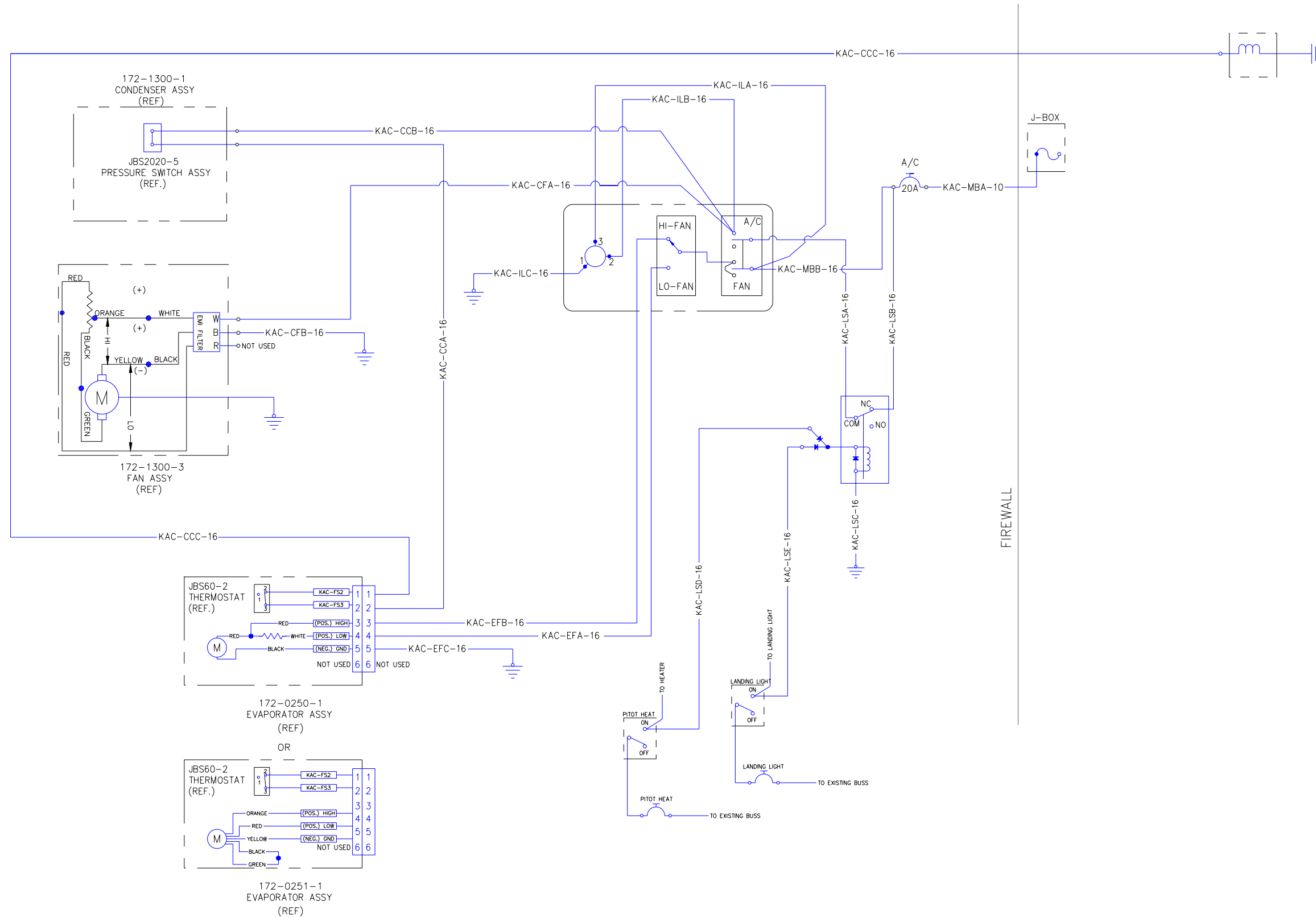

GENERAL ELECTRIC LAYOUT

ELECTRICAL

TROUBLESHOOTING

1. GENERAL

The following procedures are used for troubleshooting the electrical system and the electrical interface with the other assemblies of the air-conditioning system. The procedures systematically check every reasonable cause of the failure, starting from the power source that might result in the in operation of the evaporator blower, condenser blower, and compressor clutch. If the problem causing the component to fail is suspected, the suspected cause should be checked first. The sequence of checks may be varied to increase the convenience of the checker as desired.

A. TOOLS AND EQUIPMENT

DESIGNATION	REF. NO.	QTY.	REMARKS
Service pressure gauge	Comm. Avail	1	None
Multi-meter	Comm. Avail	1	None
28 VDC source		A/R	None

2. Evaporator Blower Doesn't Operate

- ❑ With the engine inoperative turn on the battery power
- ❑ Turn the AIR COND/OFF/FAN switch to FAN.
- ❑ Set the fan speed to high.
- ❑ Disconnect the ES53026-1 Electrical Connector from the blower.
- ❑ Check for power at pin 3. Terminal should have a voltage reading between 26.0V and 29.0V. Use a suitable aircraft ground when checking the power.
- ❑ If correct power is present at Pin 3, and Pin 4 (when selected to low), and ground is present at Pin 5, the problem lies with the evaporator/blower assembly.
- ❑ If power is not present at pin 3 and Pin 4, the problem is due to a failed electrical component, a broken electrical connection, or a broken wire on the power side of the connector.



1. Check the 30 Amp fuse, located in the J box (if applicable) for continuity. Replace as necessary
2. Check for power at the Circuit breaker. If power is not present, check the KAC-MBA-10 wire for continuity. Replace/repair as necessary.
3. Check the 20 Amp Circuit Breaker for continuity between the two wire terminals. Check the wire terminals for good connections to the wires. Replace/repair as necessary.

4. Check for power at the AIR COND/OFF/FAN Switch. If power is not present, check the KAC-MBB-16 wire for continuity. Replace/repair as necessary.
5. Check the operation of the AIR COND/OFF/FAN Switch. Check the wire terminals for good connections. Replace/repair as necessary.
6. Check for power at the Fan Speed Switch. If power is not present, replace/repair the connecting wire as necessary.
7. If power is present at the Fan Speed Switch and not at pin 3 or 4 (depending on switch positioning) of the evaporator blower connector, check the KAC-EFB-16 or KAC-EFA-16 wire for continuity. Replace/repair as necessary.

3. Condenser Blower Doesn't Operate

- With the engine inoperative turn on the battery power.
- Turn the AIR COND/OFF/FAN switch to AIR COND.
- Turn the landing light and pitot heat off.
- Check for power between the terminals of the EMI filter on the Condenser Blower Assembly.
- If the voltage measured at the EMI filter terminals is between 24.0-29.0 VDC and the blower is not operating, the blower needs to be returned for replacement/repair.
- If no voltage is measured at the EMI filter terminals, the problem is due to a failed electrical component, a broken electrical connection, or a broken wire.
 1. Check the 30 Amp fuse for continuity in J box. Replace as necessary
 2. Check for power at the Circuit breaker. If power is not present, check the KAC-MBA-10 wire for continuity. Replace/repair as necessary.
 3. Check the 20 Amp Circuit Breaker for continuity between the two wire terminals. Check the wire terminals for good connections to the wires. Replace/repair as necessary.
 4. Check for power at the ES56052-1 Relay, located in the pedestal. If power is not present, Check the KAC-LSB-16 wire for continuity. Replace/repair as necessary.
 5. Check the terminals of the ES56052-1 Relay. If there is no continuity between the KAC-LSB-16 and KAC-LSA-16 (NC and COM) wires, check for power at the relay terminal that connects to wires KAC-LSE-16, and KAC-LSD-16. There should be no power at this terminal. If there is no power, check the relay for correct wiring and replace if necessary.
 6. Check for power at the AIR COND/OFF/FAN Switch. If power is not present, check the KAC-LSA-16 wire for continuity. Replace/repair as necessary.
 7. Check the operation of the AIR COND/OFF/FAN Switch. Check the wire terminals for good connections. Replace/repair as necessary.
 8. Check for continuity from the AIR COND/OFF/FAN Switch to the positive terminal of the EMI filter. Repair/replace as necessary.
 9. Check for continuity from the Negative terminal of the EMI filter to ground. Repair/replace as necessary.

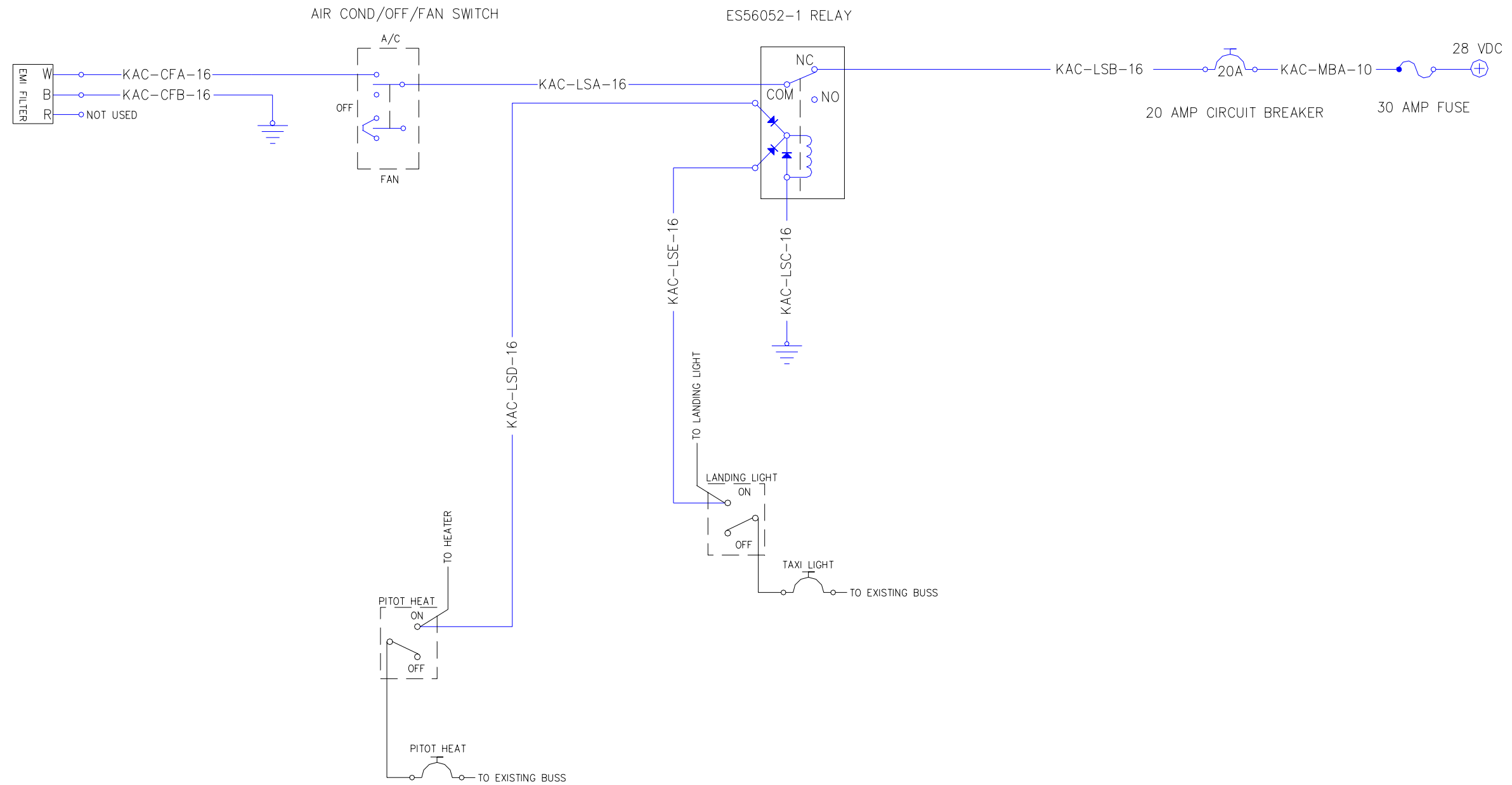

Condenser Electrical Schematic

4. Compressor Clutch Doesn't Engage

NOTE: If the ambient temperature is less than 45°F the freeze switch may disable the compressor clutch. In order to troubleshoot an inoperative compressor clutch at ambient temperatures below 45°F, use a short wire as a jumper between Pin 1 and Pin 2 of the ES53025-1 Electrical Connector on the evaporator assembly. This will bypass the temperature probes.

NOTE: The clutch will not engage with out a system charge.

- With the engine inoperative turn on the battery power.
- Turn the AIR COND/OFF/FAN switch to AIR COND.
- Turn the landing light and pitot heat off.
- Check the voltage at the positive terminal of the compressor clutch.
- If the voltage measured at the positive terminal of the compressor clutch is between 24.0-29.0 VDC, and the clutch does not engage, (it can be rotated without the compressor pulley rotating) the clutch and coil need to be returned for replacement/repair.
- If no voltage is measured at the positive terminal of the compressor clutch, the problem is due to a failed electrical component, a broken electrical connection, a broken wire, or low temperature measured by the temperature probes.

1. Check the 30 Amp fuse (at J box) for continuity. Replace as necessary
2. Check for power at the Circuit breaker. If power is not present, check the KAC-MBA-10 wire for continuity. Replace/repair as necessary.
3. Check the 20 Amp Circuit Breaker for continuity between the two wire terminals. Check the wire terminals for good connections to the wires. Replace/repair as necessary.
4. Check for power at the ES56052-1 Relay. If power is not present, Check the KAC-LSB-16 wire for continuity. Replace/repair as necessary.
5. Check the terminals of the ES56052-1 Relay. If there is no continuity between the KAC-LSB-16 and KAC-LSA-16 (NC and COM) wires, check for power at the relay terminal that connects to wires KAC-LSE-16 and KAC-LSD-16. There should be no power at this terminal. If there is no power, and NC to COM is an open circuit, check the relay for correct wiring and replace if necessary.
6. Check for power at the AIR COND/OFF/FAN Switch. If power is not present, check the KAC-LSA-16 wire for continuity. Replace/repair as necessary.
7. Check the operation of the AIR COND/OFF/FAN Switch. Check the wire terminals for good connections. Replace/repair as necessary.

8. Check for power at the JBS2020-5 Pressure Switch. If power is not present, check the KAC-CCB-16 wire for continuity. Replace/repair as necessary.
9. Check for continuity of the pressure switch. If there is no continuity at the pressure switch, check the refrigerant pressure. If the discharge pressure is between 35 and 340 PSIG, discharge the air-conditioning system and replace the JBS2020-5 Pressure Switch. If the pressure is less than 35 PSIG or greater than 340 PSIG add/remove refrigerant to the proper level.
10. Check for power at the Freeze Switch (Pin 2) on the evaporator assembly. If power is not present, check the KAC-CCA-16 wire for continuity. Replace/repair as necessary.
11. Check for continuity between Pin 1 and Pin 2. If there is no continuity between Pin 1 and Pin 2, and the ambient air temperature is greater than 45°F, replace the Freeze Switch.
12. Check for power at pin 1, If there id power at pin 1, but not at compressor, repair/replace the KAC-CCC-16 wire.

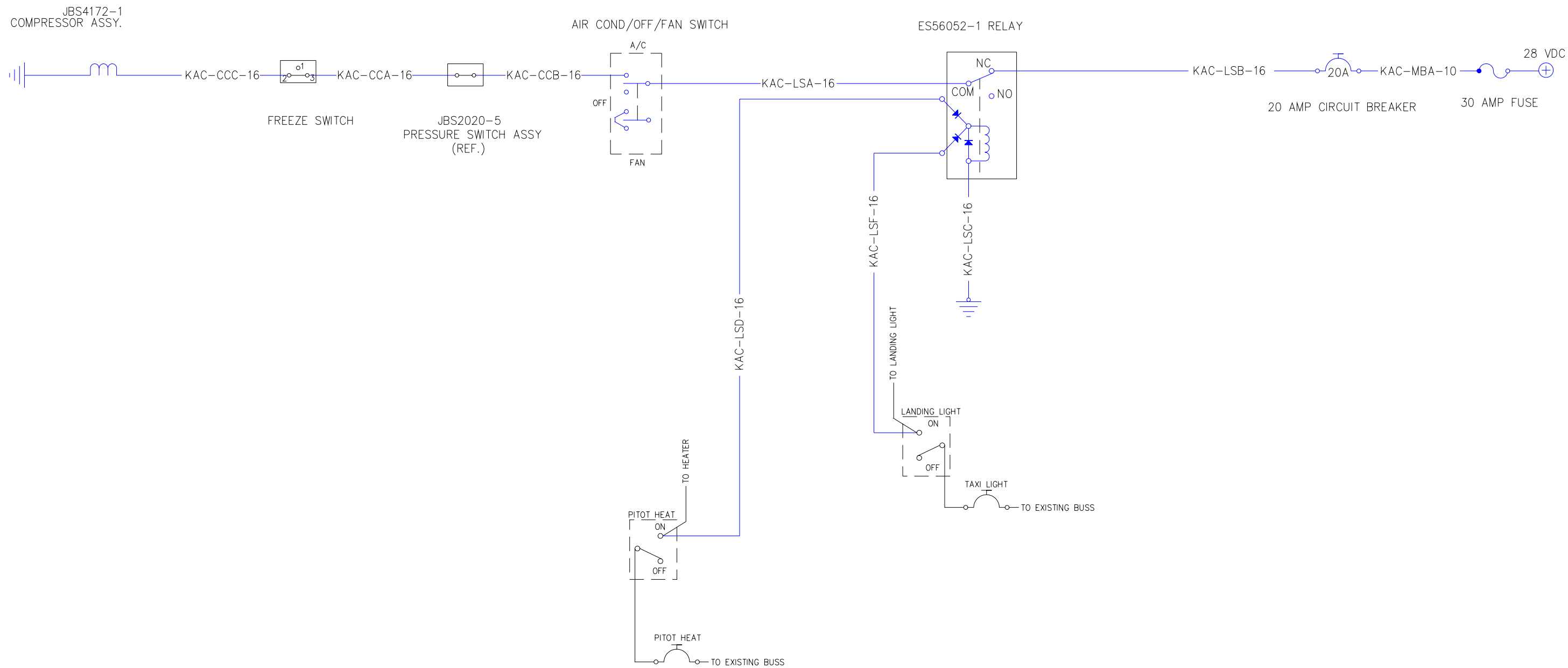

Compressor Clutch Electrical Schematic

PLUMBING

DESCRIPTION AND OPERATION

1. GENERAL

The plumbing system consists of flexible nylon lined refrigerant hose with permanent swaged on fittings. All connections are tube o-ring type with sealant on the fitting mating surfaces to ensure leak-free operation. Hose, o-ring material, and sealants are specially designed to work with refrigerant R134a and polyolester oil viscosity grade ISO 68. Two service valves are located on the right side of the aircraft near the evaporator installation. They are sized differently to avoid incorrect connection when servicing the system. A receiver/drier bottle is located downstream of the condenser to remove moisture from the liquid refrigerant. The receiver/drier bottle is mounted in the tailcone of the aircraft. A binary pressure switch monitors the refrigerant gas pressure. This switch will open at a compressor discharge over-pressure of 384 ± 29 psi and under-pressure conditions of 30 ± 5 psi. This will interrupt the power to the compressor clutch and stop the compressor.

The second overpressure safety device is a fuse plug, which will vent the system refrigerant in the event of a system pressure in excess of 425 PSIG. The R134a gas would then be sucked into the condenser blower and forced out the exhaust duct on the right side of the aircraft. It is located on the receiver/drier.

This section of the maintenance manual discusses maintenance practices used for the plumbing portion of the air-conditioning system. Refer to 172-0800 for parts list and schematics.

PLUMBING

MAINTENANCE PRACTICES

1.0 GENERAL

The following procedures are used to perform typical maintenance on the air-conditioning system plumbing.

CAUTION: Do not operate air-conditioning system with condenser air inlet or outlet blocked.

A. Connection to components, o-ring replacement:

1. Place the appropriate o-ring (reference 172-0800 drawing) over the tube "O" end of the fitting.
2. Lubricate o-ring with polyolester oil or ES49000-1 sealant prior to assembly.
3. Apply sealant to all fitting-mating surfaces prior to assembly.
4. "Dry" torque recommendations for all fittings are as follows:

Liquid hoses	11-13 ft/lbs
Discharge hoses	15-20 ft/lbs
Suction hoses	21-27 ft/lbs

It is recommended to torque to the low side of the torque range to prevent fitting twisting or damage.

B. Receiver/drier bottle replacement:

1. Replace receiver/drier bottle whenever the compressor is replaced or when the air-conditioning system plumbing is left open to the atmosphere for a period of time greater than one half (1/2) hour.

COMPRESSOR

DESCRIPTION AND OPERATION

1. GENERAL

The compressor is mounted on brackets in the engine compartment and is driven by a belt running to the starter ring-gear pulley. The compressor compresses the refrigerant gas for condensing at ambient temperatures and pumps the refrigerant through the system. The compressor clutch is powered by 28 VDC.

This section of the maintenance manual discusses maintenance practices used for the compressor assembly portion of the air-conditioning system.

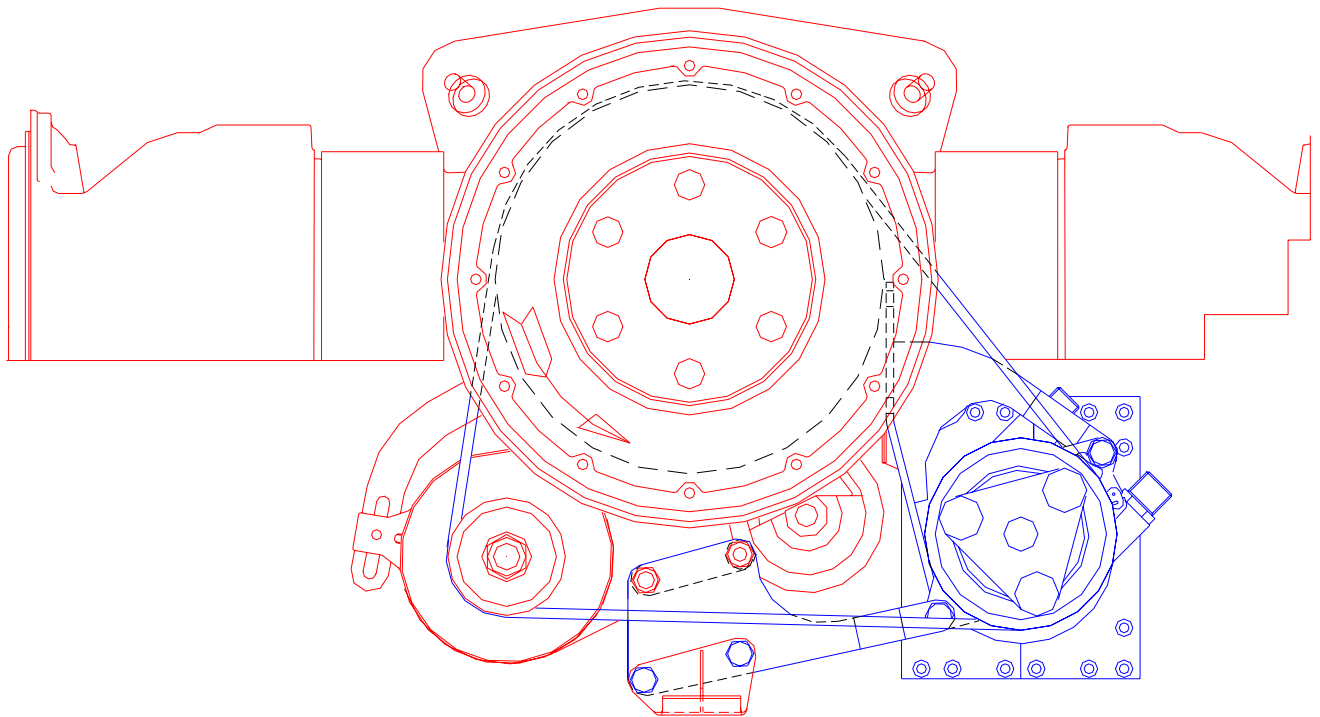

COMPRESSOR INSTALLATION

COMPRESSOR

MAINTENANCE PRACTICES

1. GENERAL

The following procedures are used to perform typical maintenance on the compressor assembly.

2. TOOLS AND EQUIPMENT

DESIGNATION	REF. NO.	QTY.	REMARKS
Polyolester oil	Comm Avail	A/R	Viscosity ISO 68

3. COMPRESSOR ASSEMBLY MAINTENANCE PROCEDURES

A. Compressor drive belt adjustment:

1. Adjust belt for moderate tension and then rotate large pulley through 2 revolutions.
2. Tension belt to deflect 0.25 inch with a 10 lb. force applied at mid-span location. The belt should deflect .5 inches with a 22 lb force applied at the mid-span location.
3. Rotate belt 5 revolutions. Re-tension as required.
4. Cessna alternator belt adjustment procedures should always take precedence over any recommendations here within.

B. Compressor oil level check:

NOTE: It is not necessary to check the compressor oil level at any time during routine maintenance as long as servicing instructions are properly followed. The compressor comes equipped with 5 oz. of polyolester oil viscosity grade ISO 68. If the amount of oil removed during system discharging and vacuuming is always added before charging, oil never needs to be added to the compressor.

CONDENSER

DESCRIPTION AND OPERATION

1. GENERAL

The condenser assembly is located in the tailcone and is attached to support structure mounted to frames in the aircraft. The assembly consists of a condenser coil unit and shroud with associated brackets. The condenser converts the refrigerant from a gas to a liquid. The receiver/drier bottle removes moisture from the refrigerant. The condenser fan draws in cool (ambient) air from the intake duct on the left side of the aircraft and blows this air through the condenser coil where the refrigerant gas can be condensed to a liquid. The air is then exhausted overboard through the exhaust duct on the right side of the tailcone.

This section of the maintenance manual discusses maintenance practices used for the condenser assembly portion of the air-conditioning system.

CONDENSER

MAINTENANCE PRACTICES

1. GENERAL

The following procedures are used to perform typical maintenance on the condenser assembly.

2. TOOLS AND EQUIPMENT

DESIGNATION	REF. NO.	QTY.	REMARKS
Vacuum Cleaner	Comm Avail	1	None
Coil Cleaner	Comm Avail	A/R	Non-acid based

3. CONDENSER ASSEMBLY MAINTENANCE PROCEDURES

A. Condenser coil cleaning procedure:

1. Remove condenser coil from aircraft and use vacuum cleaner to remove large debris from upstream and downstream coil faces.
2. Spray coil cleaner on both coil faces. Wash off with water (ends capped if not installed).
3. Allow coil to dry thoroughly prior to additional maintenance.

EVAPORATOR

DESCRIPTION AND OPERATION

1. GENERAL

The evaporator assemblies are mounted aft of the cabin on the right side of the aircraft. The evaporator assemblies are made up of an evaporator coil, and blower. Cabin air is pulled through the evaporator coil, cooled and then distributed back to the cabin.

This section of the maintenance manual discusses maintenance practices used for the evaporator assembly portion of the air-conditioning system.

EVAPORATOR

MAINTENANCE PRACTICES

4. GENERAL

The following procedures are used to perform typical maintenance on the evaporator assembly.

5. TOOLS AND EQUIPMENT

DESIGNATION	REF. NO.	QTY.	REMARKS
Vacuum Cleaner	Comm Avail	1	None
Coil Cleaner	Comm Avail	A/R	Non-acid based

6. EVAPORATOR ASSEMBLY MAINTENANCE PROCEDURES

B. Evaporator coil cleaning procedure:

1. Remove evaporator coil from aircraft and use vacuum cleaner to remove large debris from upstream and downstream coil faces.
2. Spray coil cleaner on both coil faces. Wash off with water (ends capped if not installed).
3. Allow coil to dry thoroughly prior to additional maintenance

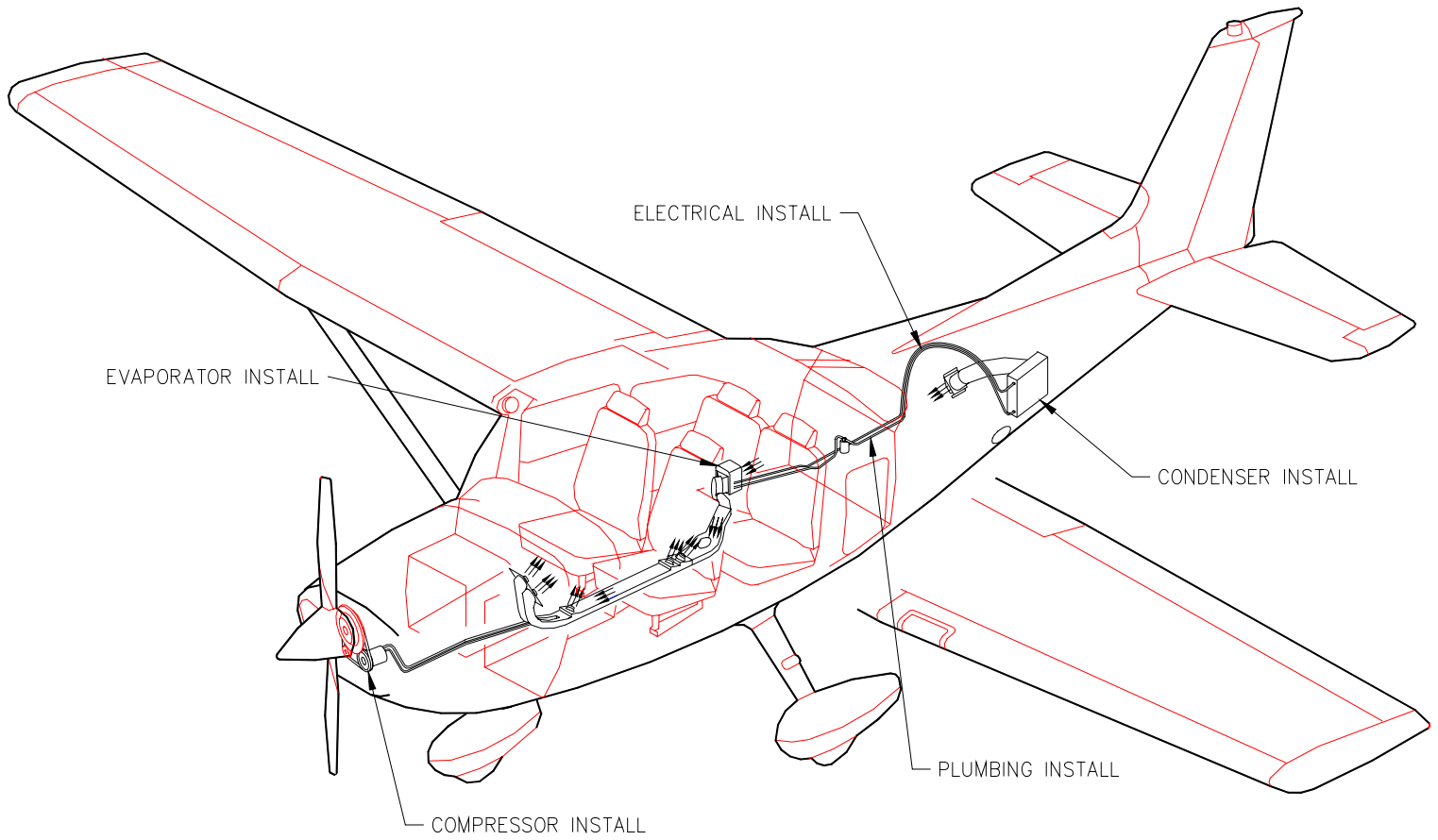

ILLUSTRATED PARTS CATALOG

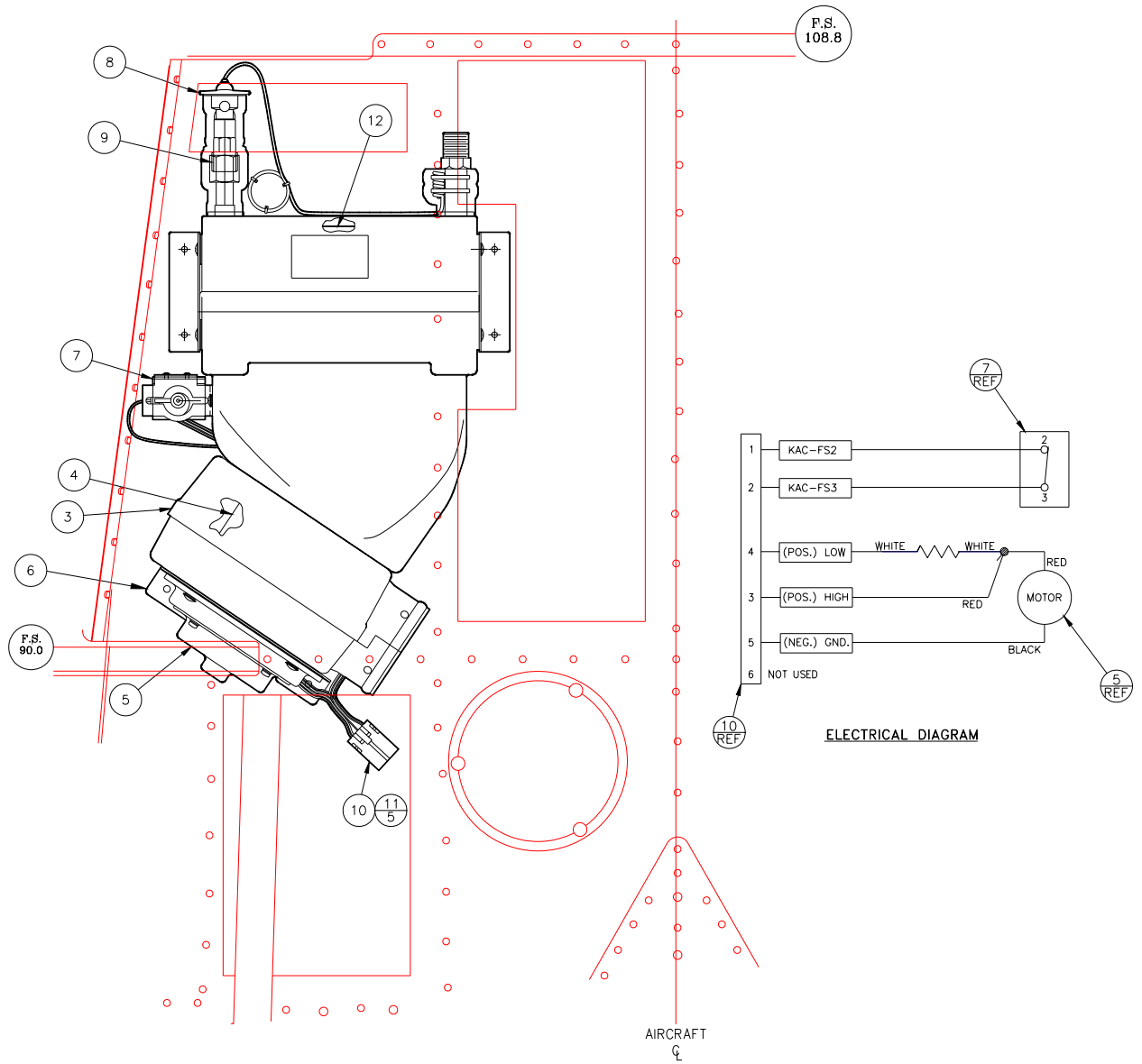
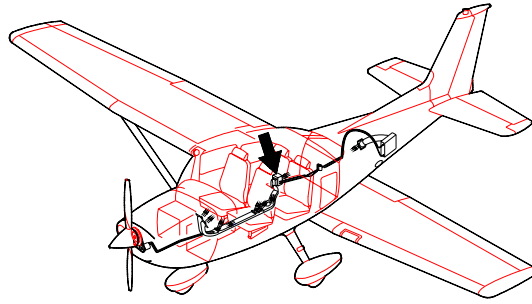

**172-0200-1 Evaporator Installation
 (172-0250-1 Configuration)**

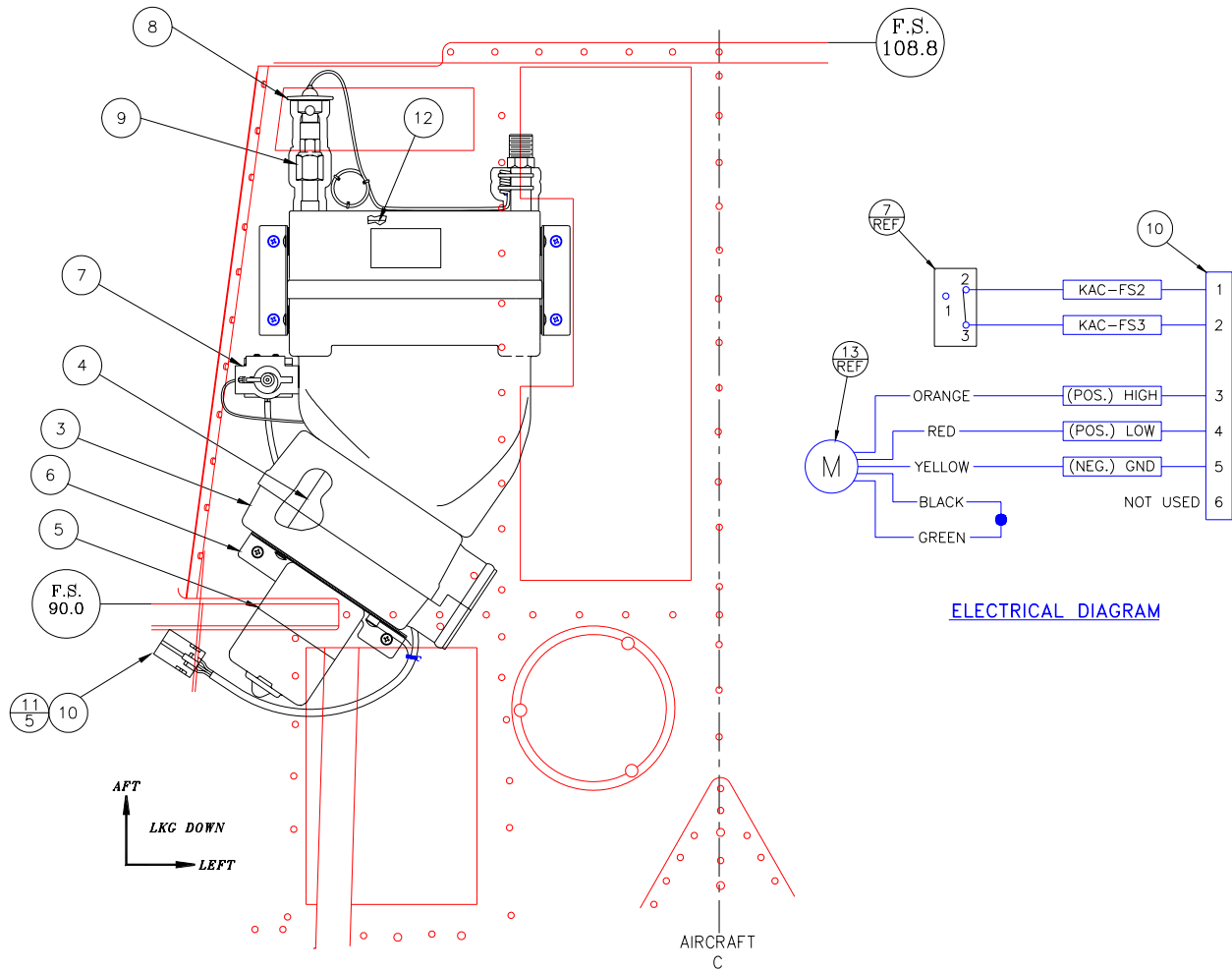
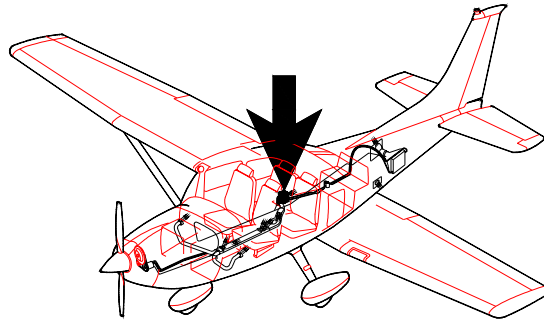

ELECTRICAL DIAGRAM

**172-0200-1 Evaporator Installation
 (172-0251-1 Configuration)**

TEM	PART NUMBER	NOMENCLATURE	UNITS PER ASSEMBLY
1	172-0200-1	Evaporator Installation	
2	172-0250-1 172-0251-1	Evaporator Assy. (Alternate Spare 172-0251-1) Evaporator Assy. (Alternate Spare 172-0250-1)	
3	JBS862-6	Blower Assembly	1
4	ES73088-10	Blower Wheel	1
5	JBS276-1 ES61060-2 ES61027-10	Motor (Use Spare ES61060-2) Motor (For 172-0250-1 Only) Motor (For 172-0251-1 Only)	1
6	172-1250-1 172-1251-1	Bracket (For 172-0250-1 Only) Bracket (For 172-0251-1 Only)	1
7	JBS60-2	Thermostat	1
8	ES26104-1	Expansion Valve	1
9	ES49011-2	O-Ring	1
10	ES53025-1	Receptacle	1
11	ES53027-2	Pin	5
12	172-0252-1	Evaporator Coil Assembly	1

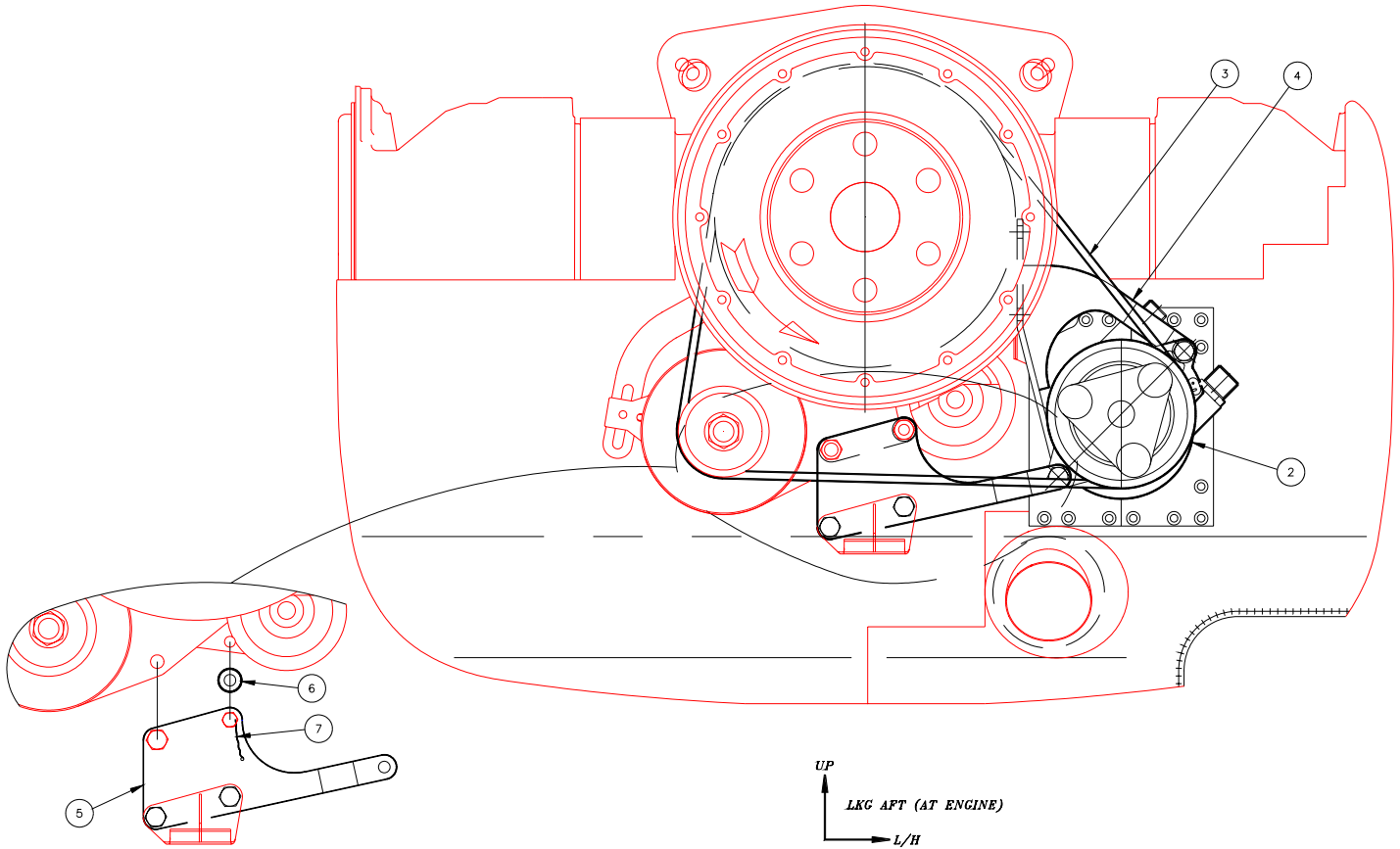
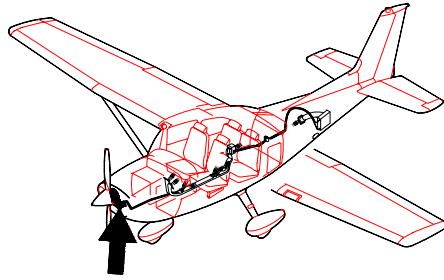

172-0400-1 Compressor Installation

ITEM	PART NUMBER	NOMENCLATURE	UNITS PER ASSEMBLY
1	172-0400-1	Compressor Installation	
2	JBS4172-1	Compressor Assembly Modification	1
3	ES20172-1	Belt	1
4	172-1400-1	Support Assembly	1
5	172-1400-9	Bracket	1
6	172-1400-6	Spacer	1
7	MS20995C32	Safety Wire	A/R

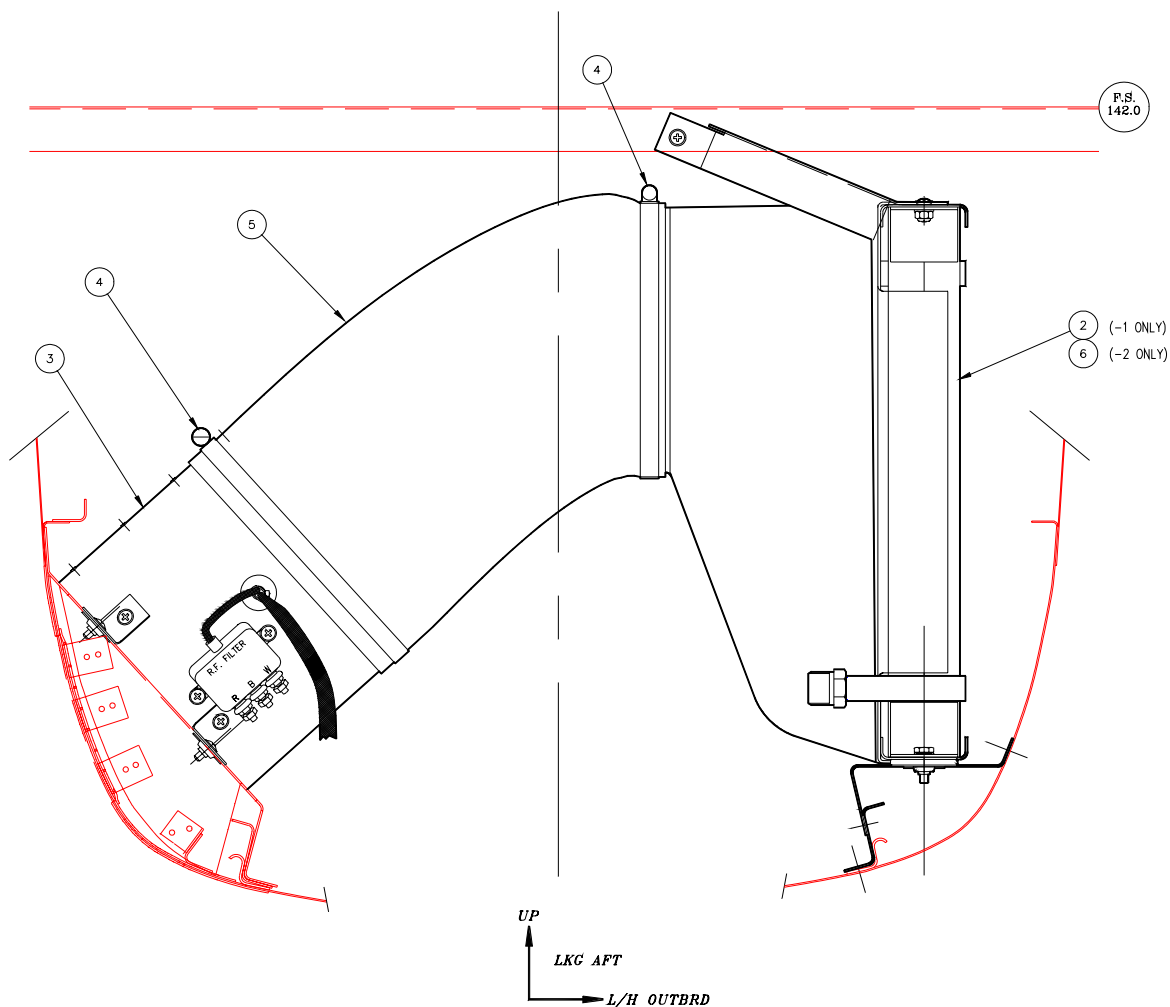
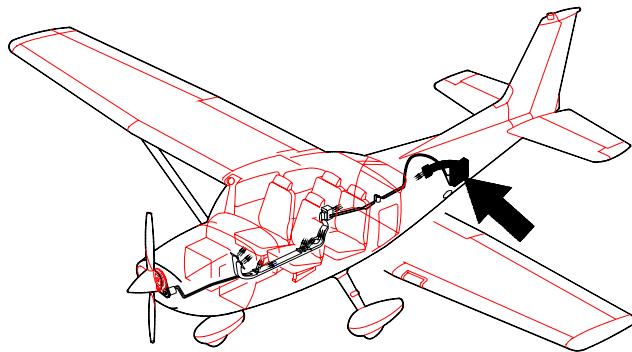

172-0300-1 Condenser Installation
172-0300-2 Condenser Installation

ITEM	PART NUMBER	NOMENCLATURE	UNITS PER ASSEMBLY
1	172-0300-1,-2	Condenser Installation	
2	172-1300-1	Condenser Assembly (-1 only)	1
3	172-1300-3	Fan Assembly	1
4	ES30042-10	Clamp	2
5	ES70009-7	Flex Duct (in.)	15
6	172-1300-7	Condenser Assembly (-2 only)	1

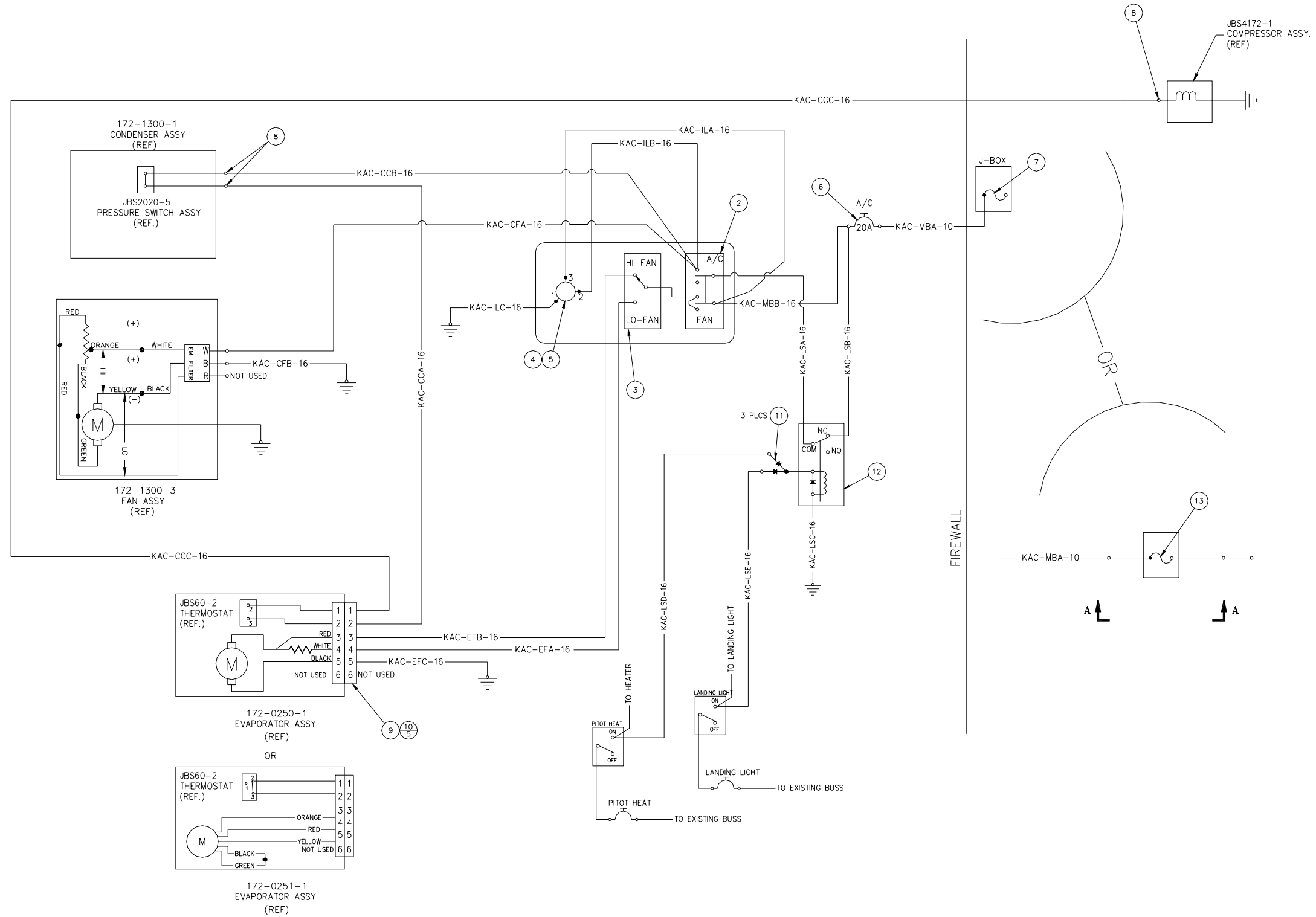

172-0700-1 Electrical Installation

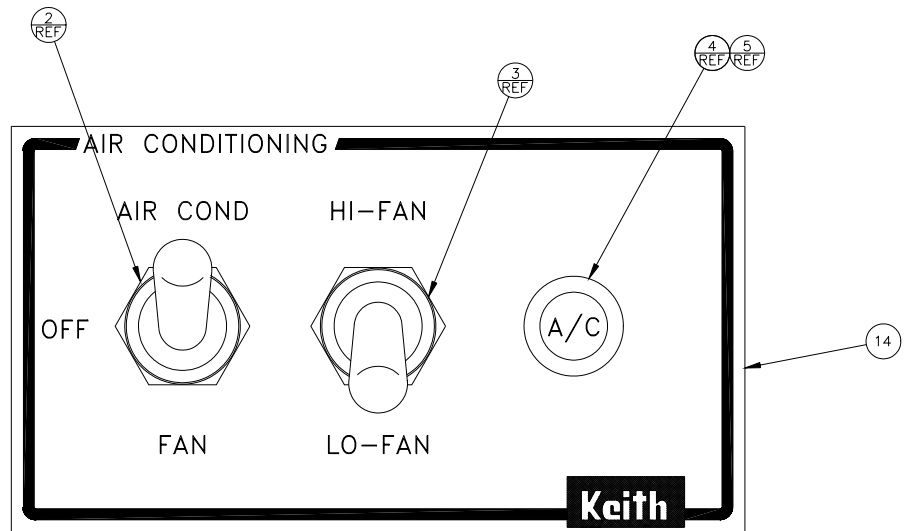

SWITCH PANEL

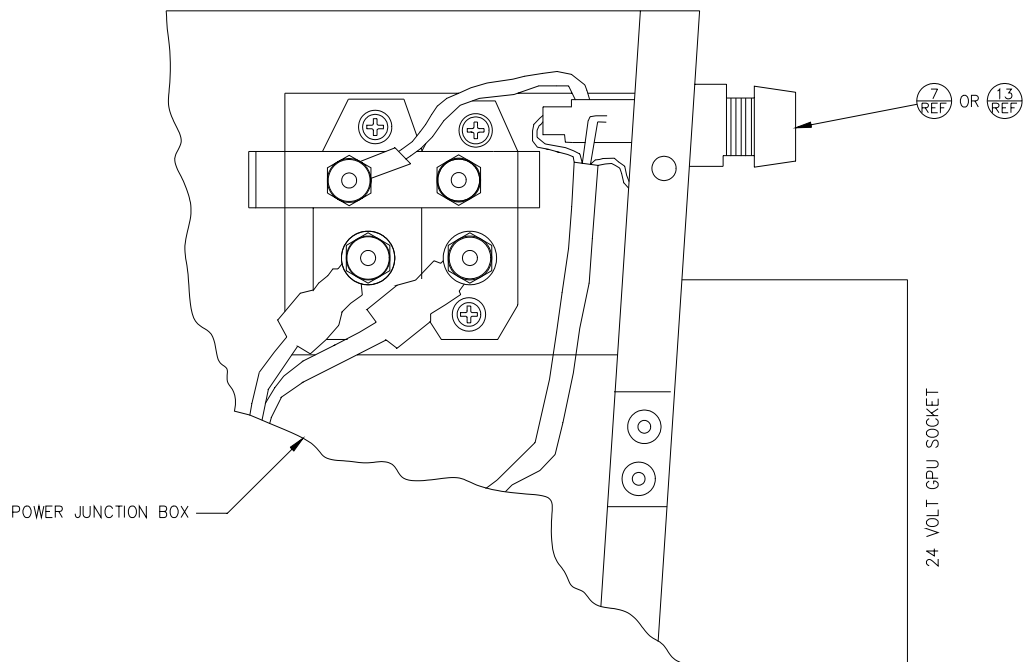

VIEW A-A

Keith Products, Inc.
CR-172-15 System Service Manual

ITEM	PART NUMBER	NOMENCLATURE	UNITS PER ASSEMBLY
1	172-0700-1	Electrical Installation	
2	ES57016-5	Switch	1
3	ES57016-6	Switch	1
4	MS25041-10	Light Indicator	1
5	ES50162-1	Lamp	1
6	ES51000-1	Circuit Breaker (20A)	1
7	ES51172-1	Fuse (30A)	1
8	ES55079-1	Splice, Knife Disconnect	3
9	ES53026-1	Plug	1
10	ES53028-2	Socket	5
11	ES58161-15	Diode	3
12	ES56052-1	Relay	1
13	JBS64-13	Fuse (30A)	1
14	JBS7002-3	Panel, Switch	1

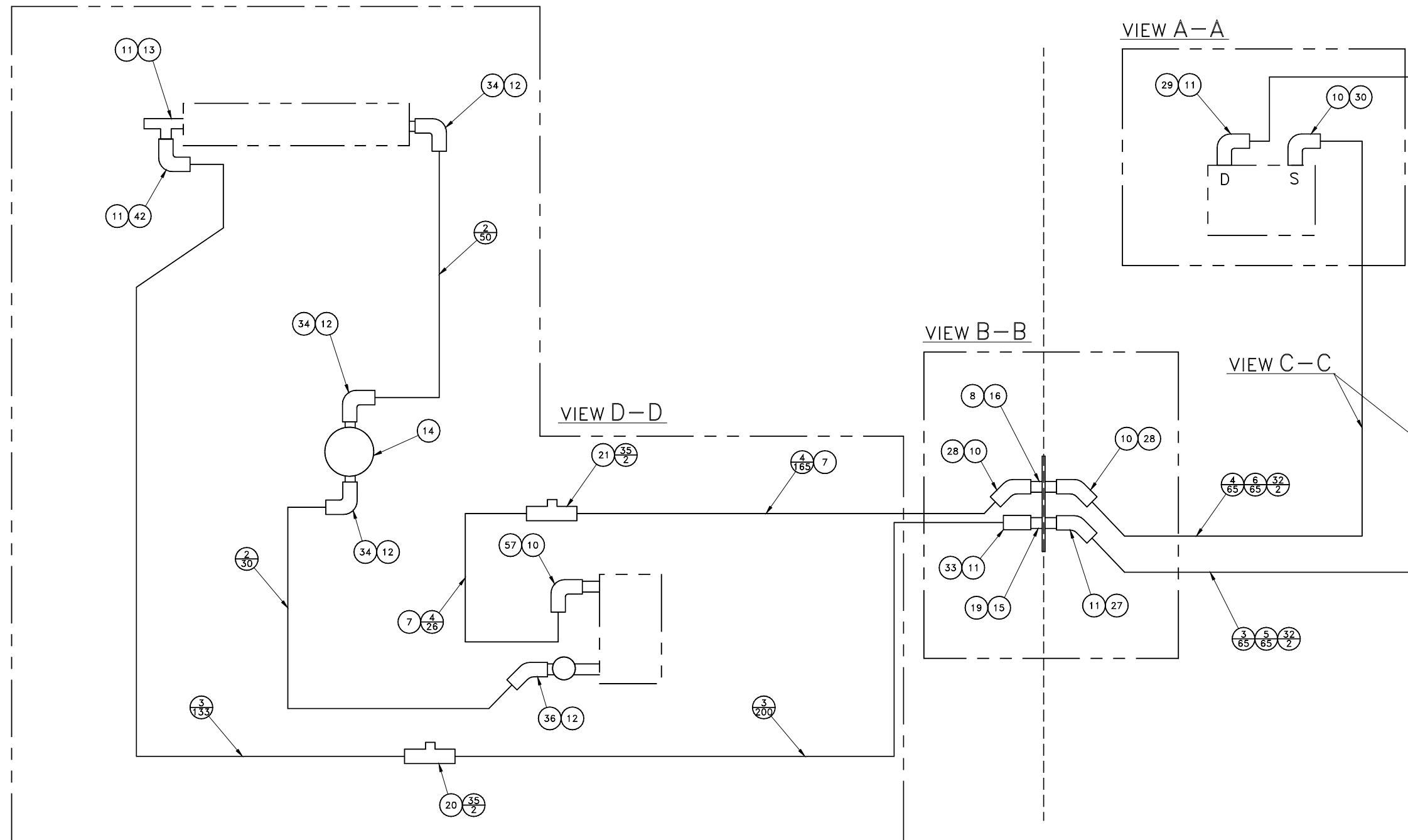

172-0800-1 Plumbing Installation

Keith Products, Inc.
CR-172-15 System Service Manual

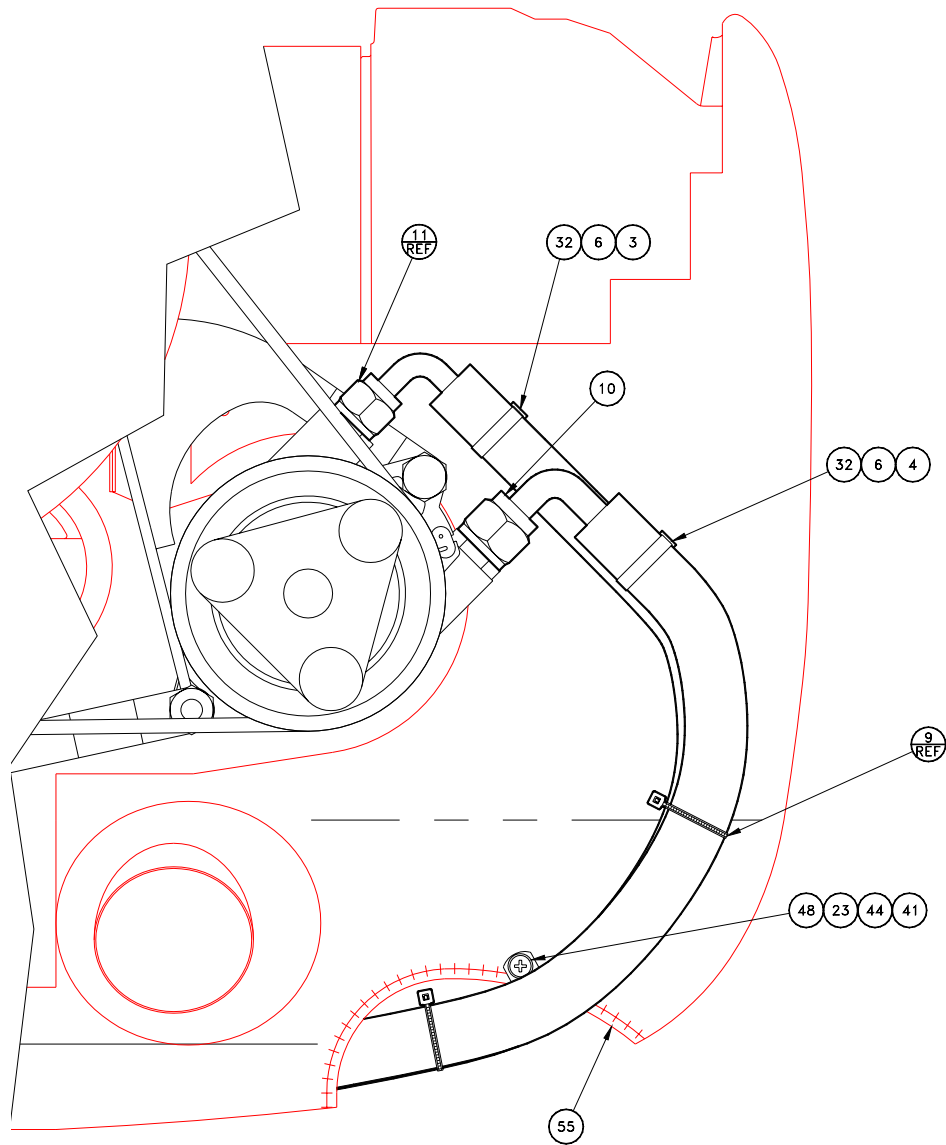

UP
LKG AFT
(AT ENGINE)
RIGHT

VIEW A-A

Keith Products, Inc.
 CR-172-15 System Service Manual

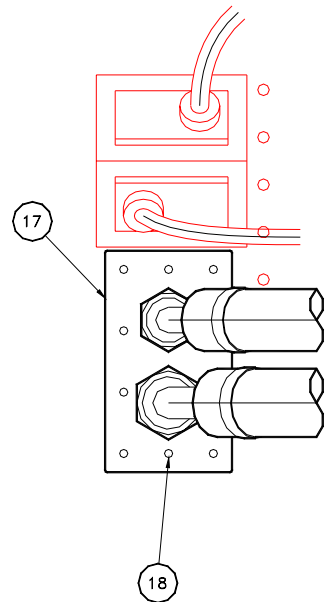

VIEW E-E

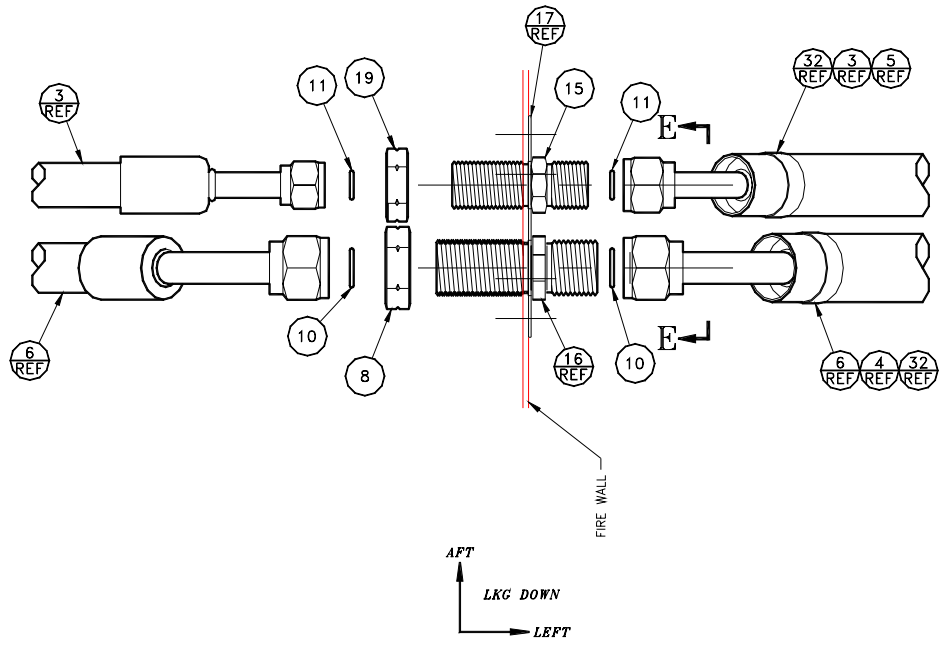

VIEW B-B

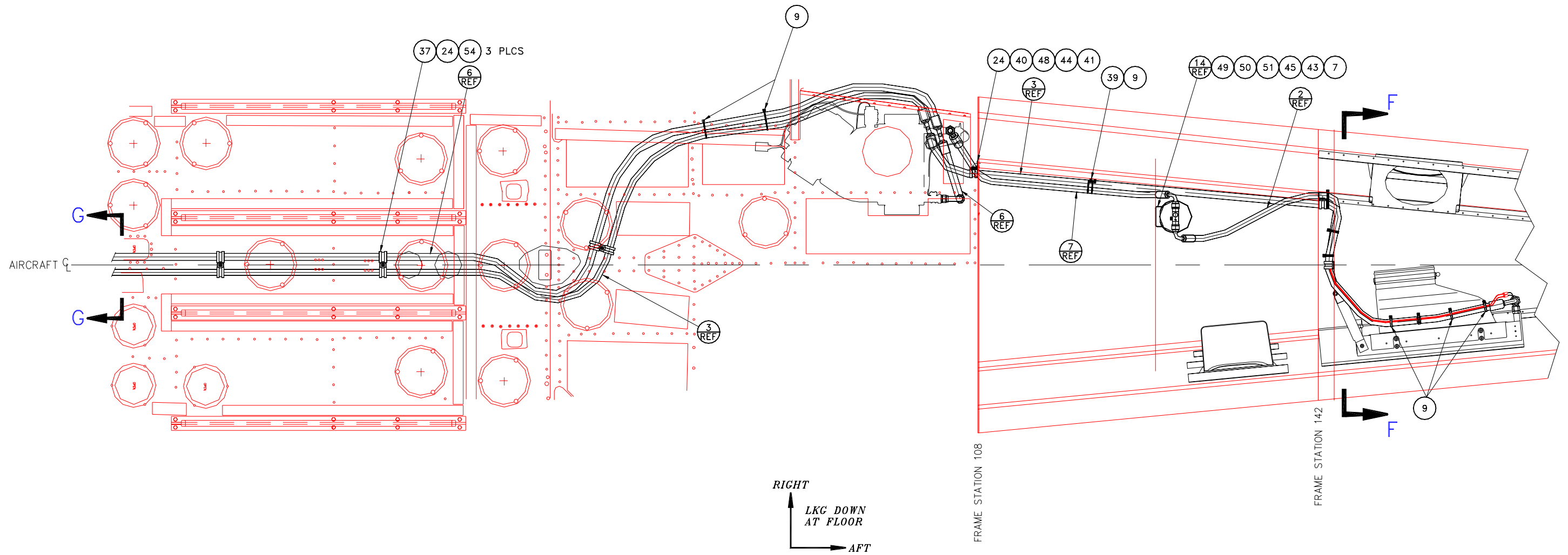

VIEW D-D

Keith Products, Inc.
CR-172-15 System Service Manual

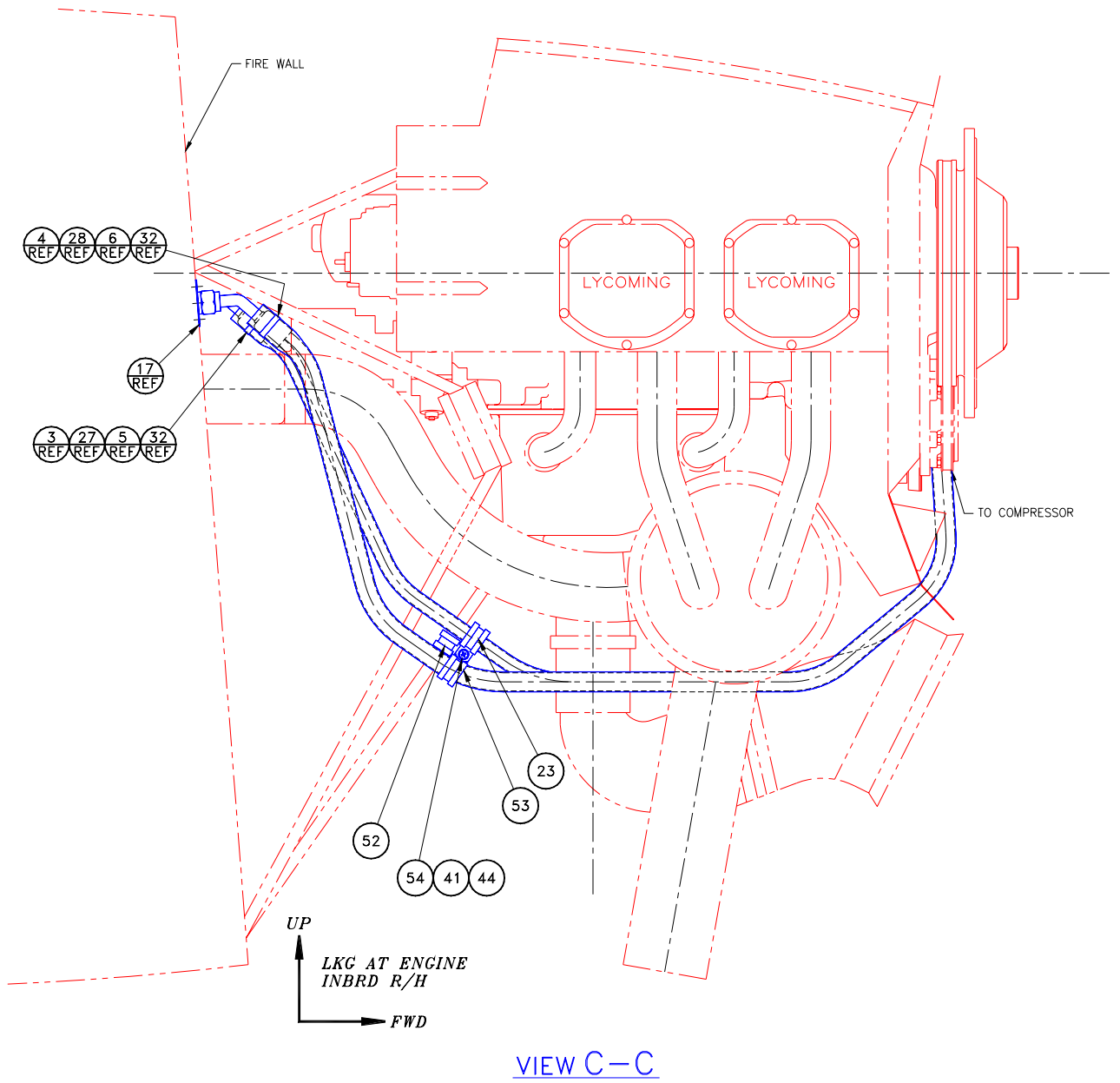

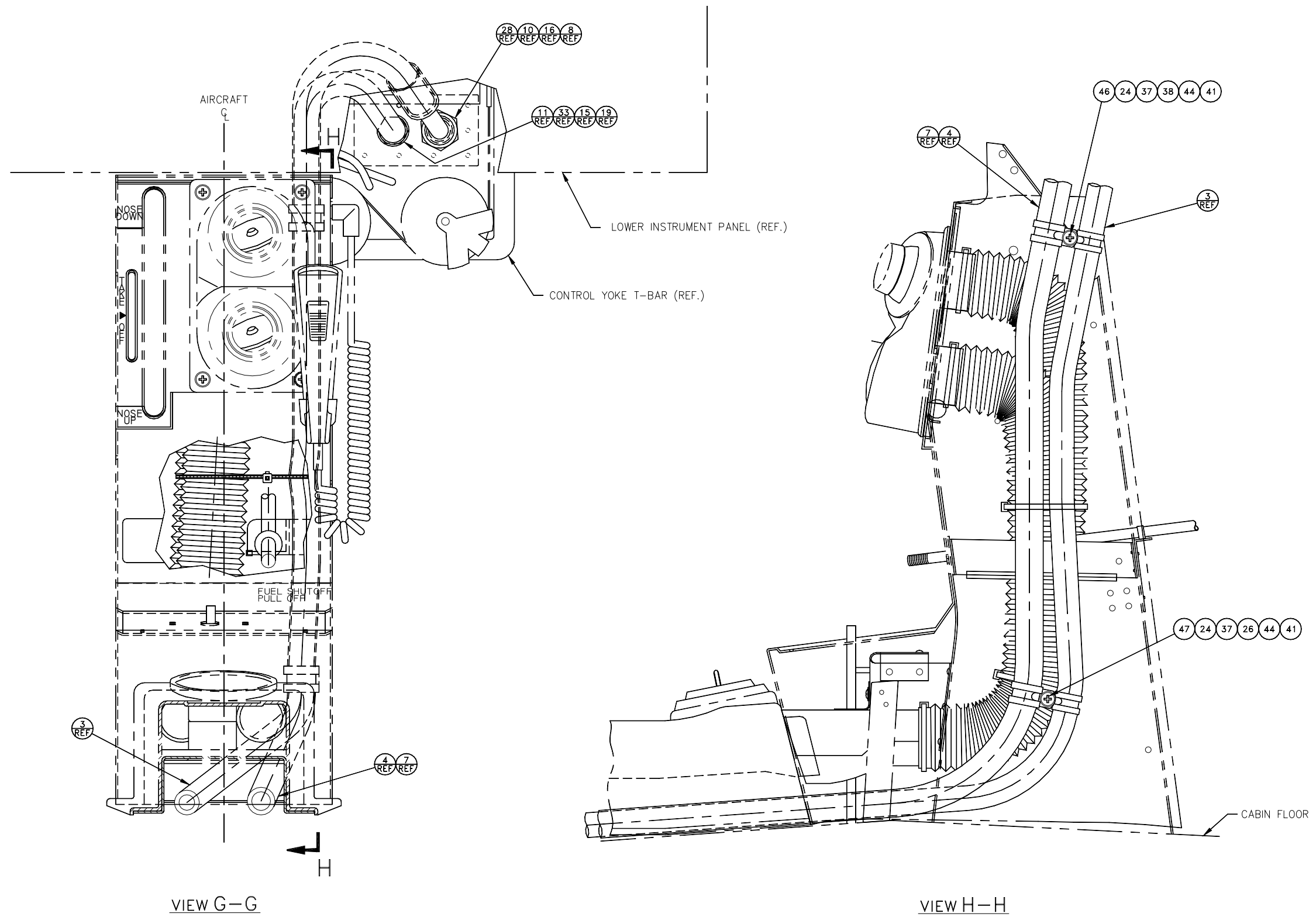

Keith Products, Inc.
CR-172-15 System Service Manual

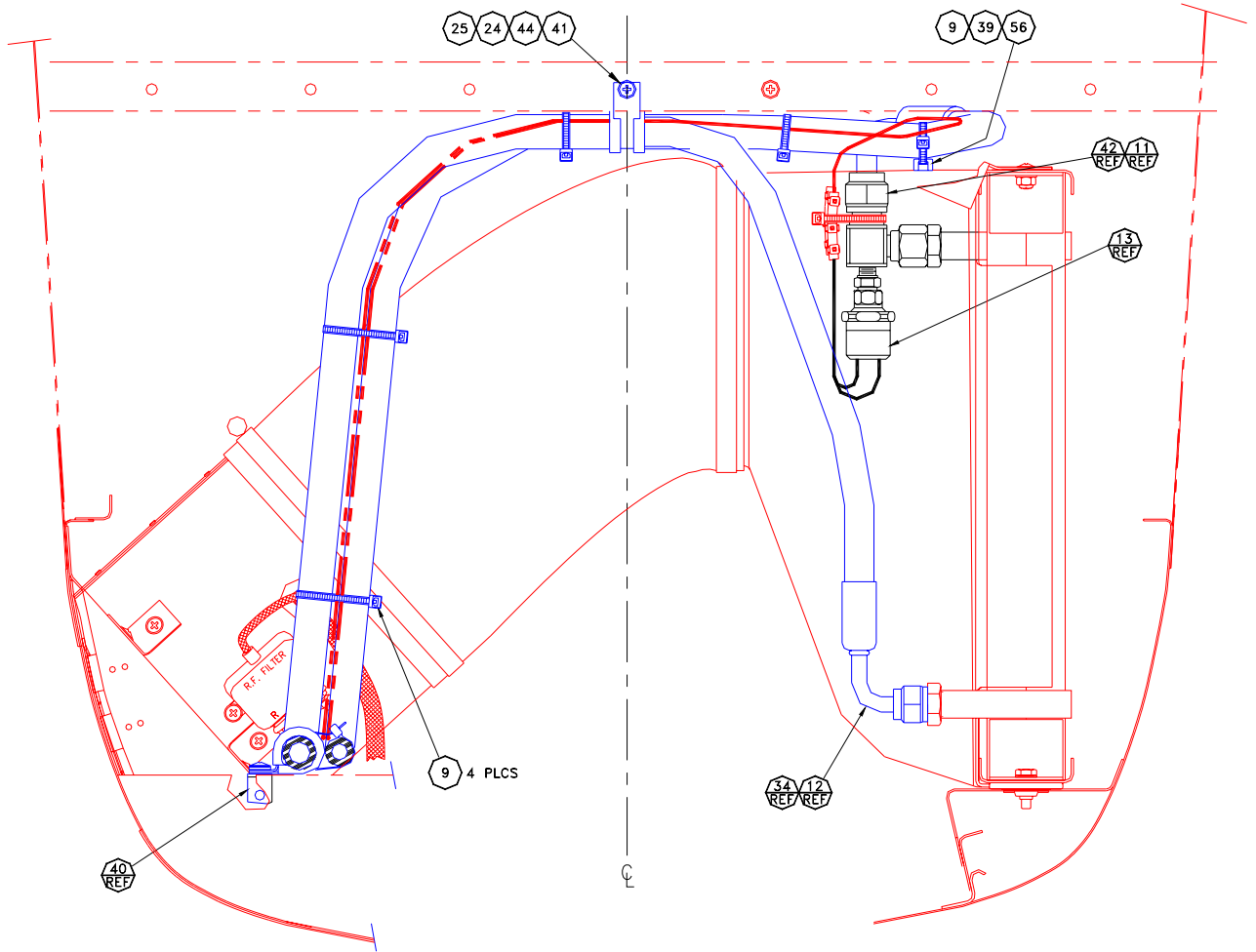

VIEW F-F

Keith Products, Inc.
CR-172-15 System Service Manual

ITEM	PART NUMBER	NOMENCLATURE	UNITS PER ASSEMBLY
1	172-0800-1	Plumbing Installation	
2	ES48149-1	Hose (IN)	80
3	ES48149-2	Hose (IN)	406
4	ES48149-3	Hose (IN)	262
5	ES02126-1	Fire Sleeve (IN)	65
6	ES02126-2	Fire Sleeve (IN)	65
7	ES06022-1	Insulation Tape (IN)	720
8	AN6289-10D	Nut	1
9	ES30015-6	Cable tie	20
10	ES49011-3	O-Ring	4
11	ES49011-2	O-Ring	5
12	ES49011-1	O-Ring	4
13	JBS2020-5	Pressure Switch Assembly	1
14	ES43030-2	Receiver Dryer	1
15	JBS6009-9	Fitting, Bulkhead O-Ring	1
16	JBS6009-3	Fitting, Bulkhead O-Ring	1
17	172-1800-2	Doubler	1
18	ES31101DS4-2	Rivet	10
19	AN6289-8D	Nut	1
20	ES40158-2	Splicer, Beadlock	1
21	ES40158-3	Splicer, Beadlock	1
22	ES49000-1	Sealant	1
23	MS21919WDG16	Hose Clamp	2
24	MS21919WDG11	Hose Clamp	8
25	AN525-10R8	Screw	1
26	NAS43DD3-13	Spacer	1
27	ES40150-2	Fitting	2
28	ES40150-3	Fitting	2
29	ES40159-1	Fitting	1
30	ES40159-2	Fitting	1
31	AN960-4L	Washer	1
32	ES30072-1	Band-It Clamp	4
33	ES40149-2	Fitting	1
34	ES40151-1	Fitting	3
35	JBS10-64	Placard	4
36	ES40150-1	Fitting	1
37	MS21919WDG14	Hose Clamp	5
38	NAS43DD3-25	Spacer	1
39	ES30013-2	Tie Block	1
40	MS9592-005	Bracket	2
41	MS20365-1032	Nut	9

Keith Products, Inc.
CR-172-15 System Service Manual

ITEM	PART NUMBER	NOMENCLATURE	UNITS PER ASSEMBLY
42	ES40151-2	Fitting	1
43	MS21044N08	Nut	2
44	AN960-10	Washer	9
45	AN960-8	Washer	2
46	AN525-10R14	Screw	1
47	AN525-10R12	Screw	1
48	AN525-10R7	Screw	5
49	206-1357-8	Bracket	1
50	ES30042-6	Clamp, Aero-Seal	1
51	AN525-832R6	Screw	2
52	MS21919WDG12	Clamp	1
53	MS21919WDG20	Clamp	1
54	AN525-10R10	Screw	4
55	MS21266-1N	Grommet Strip (IN)	12
56	ES30013-1	Tie Block	1
57	ES40151-3	Fitting	1

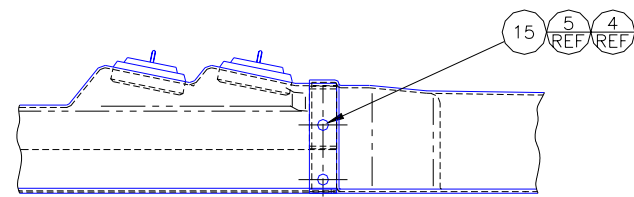
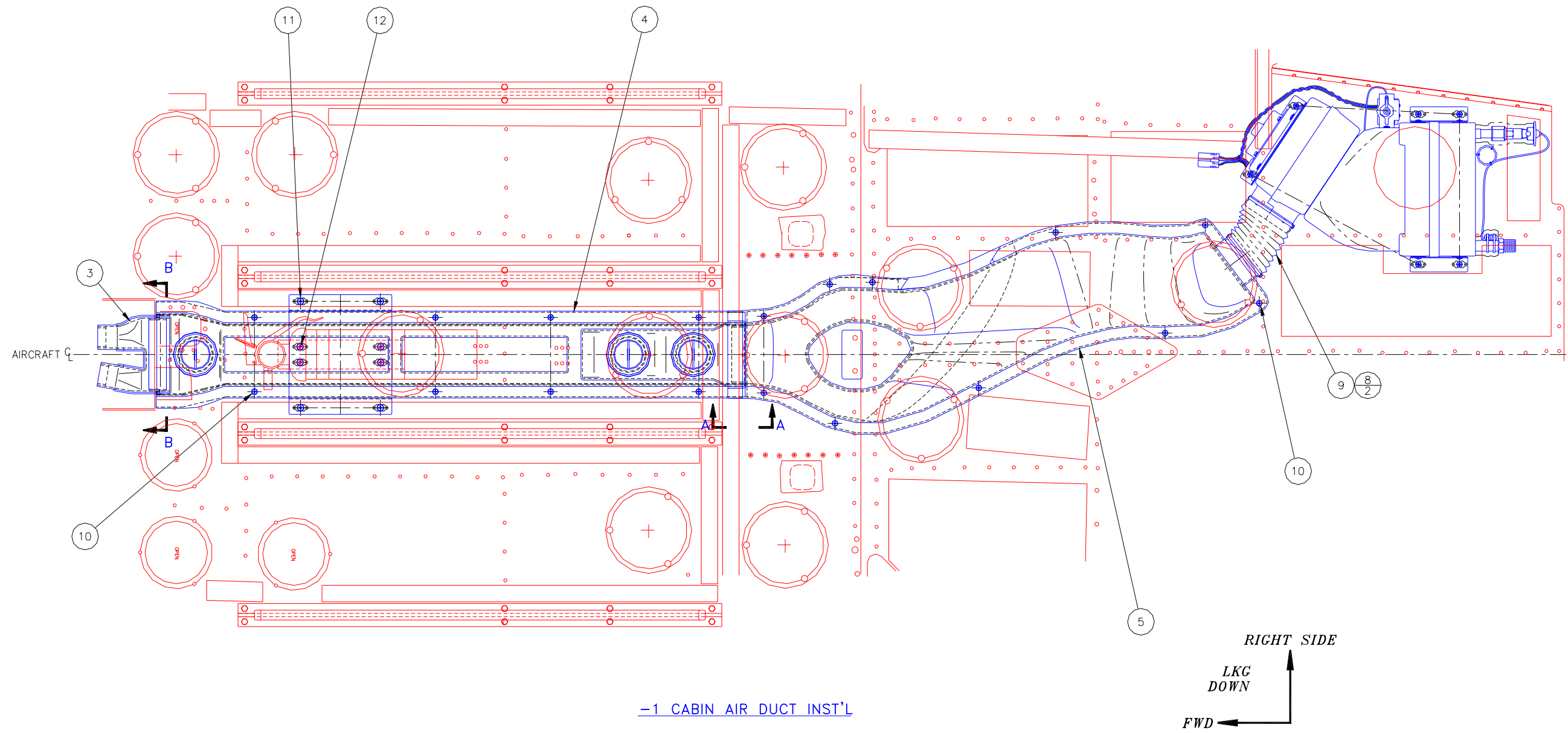

VIEW A-A

172-0600-1 Cabin Air Duct Installation

Keith Products, Inc.
CR-172-15 System Service Manual

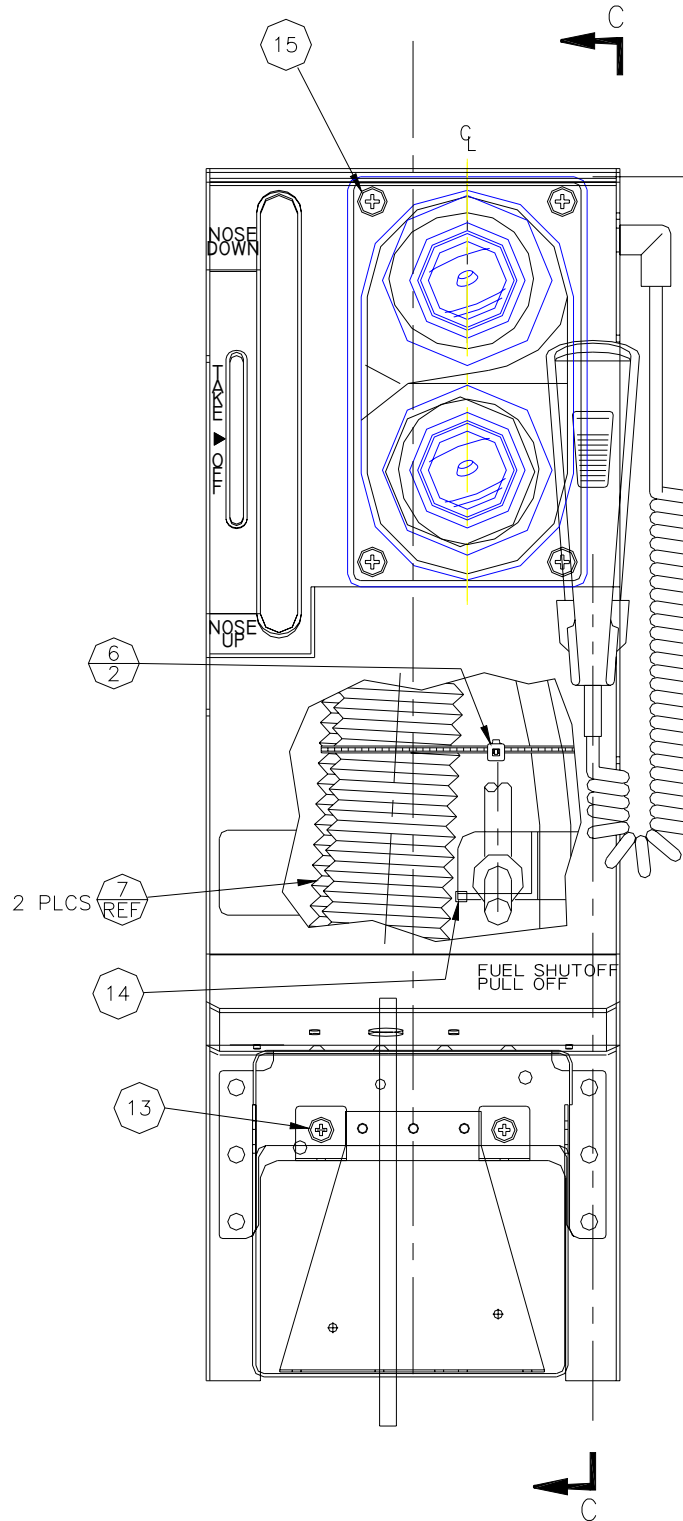

VIEW A-A

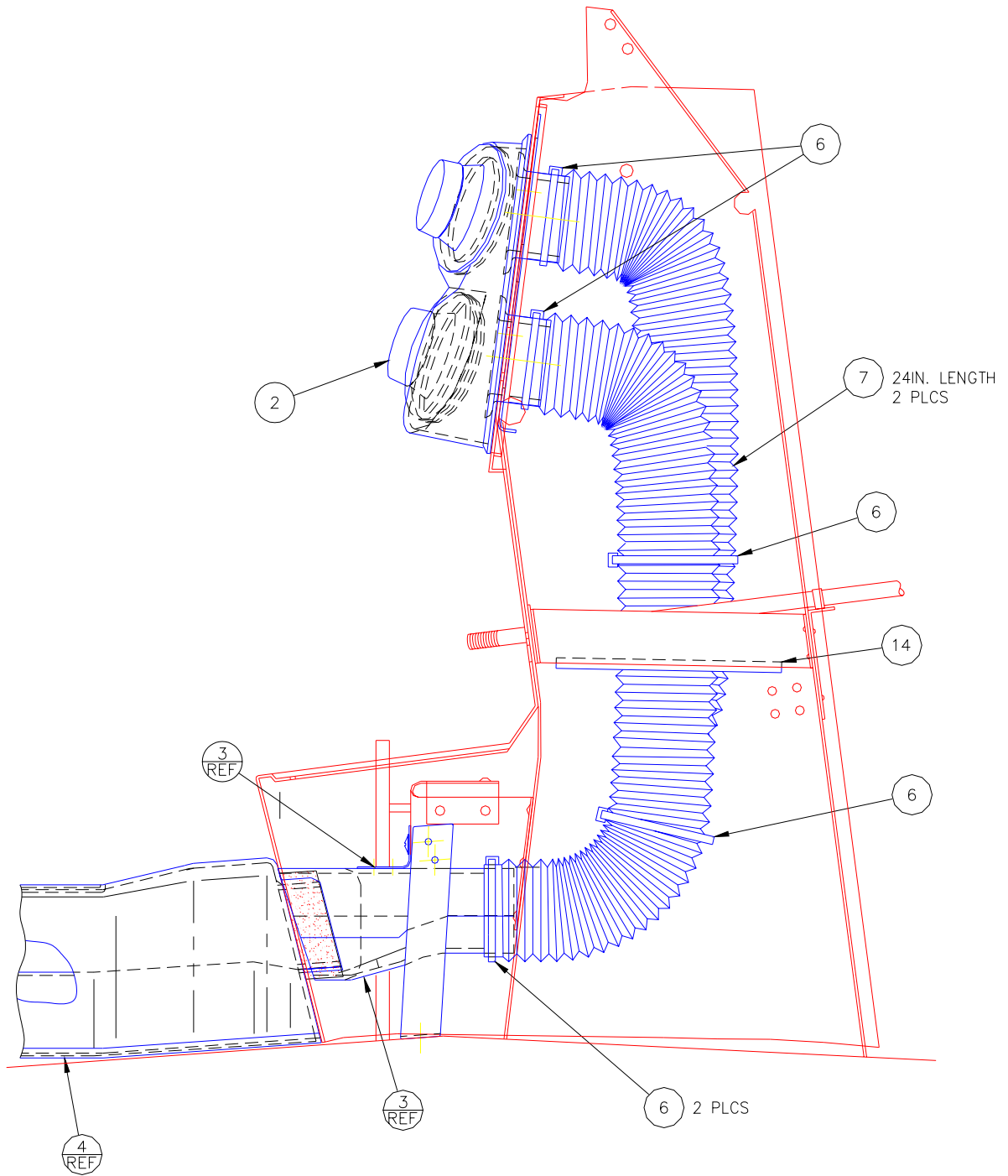

VIEW C-C
EXISTING MIC
OMITTED FOR CLARITY

Keith Products, Inc.
CR-172-15 System Service Manual

ITEM	PART NUMBER	NOMENCLATURE	UNITS PER ASSEMBLY
1	172-0600-1	Cabin Air Ducting Installation	
2	172-0650-1	Air Outlet Assembly	1
3	172-0650-2	Duct Assembly	1
4	172-0650-3	Center Duct Assembly	1
5	172-0650-4	AFT Duct Assembly	1
6	ES30015-1	Cable Tie	8
7	ES70009-4	Flex Duct (IN)	60
8	MS3367-2-0	Cable Tie	2
9	ES70009-2	Flex Duct (IN)	6
10	AN525-832R12	Screw	18
11	AN525-10R10	Screw	4
12	AN525-10R6	Screw	4
13	AN525-832R8	Screw	2
14	MS21266-1N	Grommet, Plastic Edge (IN)	6
15	AN525-832R10	Screw	8