

Service Kit

FAA-DER APPROVED

Service Kit Instructions SK-S-6019EC-1-3

Title: Spares Replacement of Evaporator Blowers

Applicability: Eurocopter Model 130 equipped with Air Comm Corporation Air Conditioning Systems.

Date: September 12, 2008

Compliance: This is a spares replacement change.

Background: This kit provides for the replacement of the existing evaporator blower motor with an alternate motor.

This change is required because the original motor is no longer available.

Bill of Materials:

Items to be removed

Item	Part Number	Description	QTY.
1	ES61060-2 or ES61062-1	Motor	1
2	AN525-8R10	Screw	4

Items to be installed

Item	Part Number	Description	QTY.
1	S-61064-1	Motor	1
2	S-6019EC-1	Adapter Assy	1
3	MS21042L3	Nut	6
4	NAS1149F0332P	Washer	6
5	MS24693-S273	Screw	4

Please Contact Air Comm Corp Service Department for parts listed above.
 Phone # 303-440-4075 Fax # 303-440-6355 or info@aircommcorp.com

CAUTION

Disconnect Battery and External Power from aircraft before starting work.

Replacement of Forward Evaporator Motor

1. Disconnect existing Molex connector from forward evaporator wiring harness.
2. Remove four screws holding motor assembly into evaporator enclosure.
3. Loosen retaining set screw and remove blower wheel from motor shaft. Retain blower wheel.

NOTE

It may be necessary to apply heat to the set screw of the blower wheel to separate the two parts.

4. Install existing blower wheel on new motor. Press the blower wheel onto the motor shaft until it stops against motor. Back blower wheel away to achieve a .030”-.040” clearance between blower wheel and new motor. Apply one drop of low strength Loctite to set screw and tighten against flat portion of motor shaft to lock wheel in place. (Figure 1.0)
5. Install S-6019EC-1 Adapter Assembly onto to evaporator assembly using 4 each MS24693-S273 screws. (Figure 2.0)
6. Install S-61064-1 motor/blower wheel assembly into evaporator enclosure using 6 each NAS1149F0332P washers and 6 each MS21042L3 nuts (Figure 2.0). Care should be taken to orient new electrical leads with existing wires to aid in final attachment to evaporator housing.
7. Connect existing forward evaporator wiring harness to new motor wiring.

NOTE

Due to the proximity of the flight controls care should be taken to ensure all electrical connections are properly insulated and secured.

8. After connecting new motor into the existing wiring harness perform an electrical check to ensure both evaporator blowers are running in the proper direction. Observe blower wheel rotation from blower outlet. Blower wheel should rotate toward blower outlet.
9. Return the Air Conditioner to service.

Install existing blower wheel on new motor. Press the blower wheel onto the motor shaft until it stops against motor. Back blower wheel away to achieve a .030"-.040" clearance between blower wheel and new motor. Apply one drop of low strength Loctite to set screw and tighten against flat portion of motor shaft to lock wheel in place.

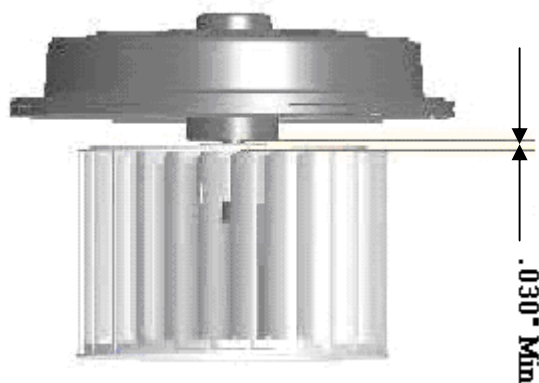

Figure 2.0 Blower Wheel / Motor Assy

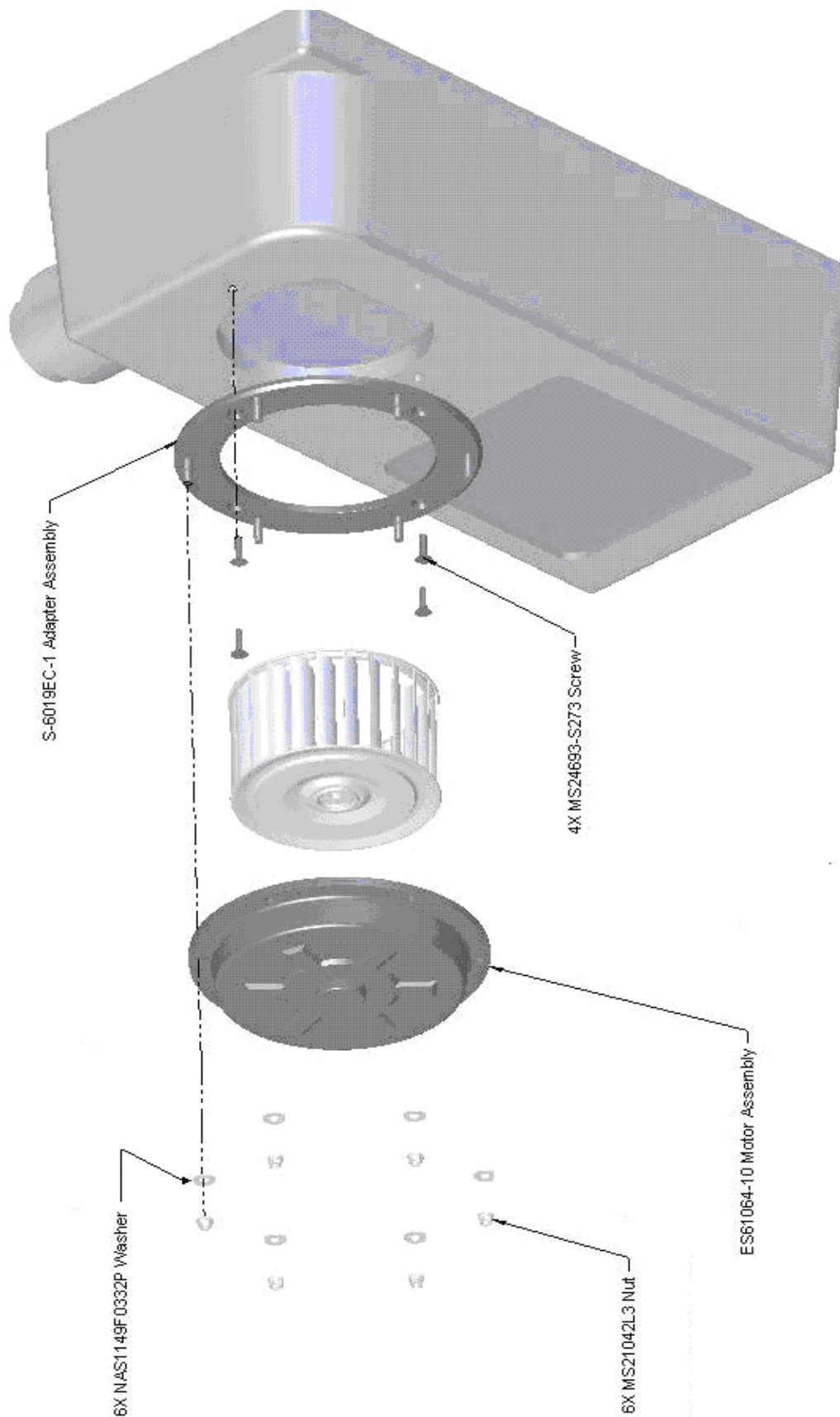

Figure 2.0 Blower Motor / Wheel Evaporator installation