

Air Comm Corporation
Boulder, CO 80301

S76H-200M

Installation Instructions –
Sikorsky S-76 Cabin Heater/Defroster

This document contains:

Installation Instructions
Weight & Balance Data
Service Manual Supplement
Flight Manual Supplement
STC Certificate

April 12, 1990

Revisions

<u>Rev</u>	<u>Date</u>	<u>Description</u>	<u>Appl</u>
A	11-21-94	Revised Document to add S-76C data. Added SI-S76H-6 to section II.	NS
B	10-21-03	Revised document to add -17, -18 -19 and -20 weight data.	NS
C	10-11-05	Revised Page 3 of 5 Maintenance Instructions from annually to not to Exceed two years.	NS

Table of Contents

<u>Item</u>	<u>Page</u>
Introduction	1
Reference Documents	1
Installation Instructions	2
Weight and Balance Data	3
Service Manual Supplement	II-1
Flight Manual Supplement	III-1
STC Certificate	IV-1

Introduction

This document presents a step-by-step procedure for installation of the ACC S76H-100 Cabin Heater System in the Sikorsky S-76 Helicopter. The instructions contained herein are intended to supplement the information contained on the installation drawings.

This manual provides additional information which is required for operation and maintenance of the aircraft. This data is contained in the last three sections of this report. After completion of this installation, the applicable sections are to be removed from this document and placed with the appropriate aircraft documents.

Reference Documents

Air Comm Corporation installation drawings:

- S76H-100; General Arrangement – Sikorsky S76 Cabin Heater
- S76H-505; Installation – Sikorsky S76 Bleed Air Plumbing
(Applicable to an S-76A previously equipped with a bleed air heater)
- S76H-508; Installation – Sikorsky S76 Bleed Air Plumbing
(Applicable to an S76B previously equipped with an ECU)
- S76H-505; Installation – Sikorsky S76A Bleed Air Plumbing
(Applicable to an S-76A previously equipped with a ECU)
- S76H-526; Installation – Sikorsky S-76C Bleed Air Plumbing
(Applicable to an S76C previously equipped with a cabin heater.
- S76H-554; Installation – S76 Heater/Defroster Valve
- S76H-906; Installation – Flight Deck Heater
- S76H-925; Installation – Sikorsky S76 Cabin Heater (optional)
- S76H-965; Installation – Sikorsky S76 Windshield Defroster

Installation Instructions

General Procedures

Before beginning the installation, it is suggested that the installer review the contents of this document and all drawings. Both the notes and the drawing details should be reviewed.

To insure that all drawing details are accomplished, it is suggested that these details be marked through with a “highlighter” as the installation progresses.

To accomplish the installation it is necessary to remove the headliner panels between Stations 120 and 215 and the floor panels between Stations 83 and 148.

Installation Procedures

The installation details are provided by the referenced installation drawings. The following step-by-step procedure is intended to supplement the data presented by the drawing.

1. The plumbing system should be installed first by starting at the station 215 bulkhead.
2. The tubing sections should be installed loose from station 215 to the valve installation.

Note

Form tubes as required to achieve tube fit alignment. Exact location of bulkhead penetrations should be determined by tube geometry.

Note

Install tube joint insulation (Firesleeve) Sections (see Dwg S76H-505, pg. 10) before joining tube sections.

3. Locate and install valve assembly according to drawing S76H-554.
4. Clamp plumbing from station 214 to the valve assembly.
5. Install plumbing to heater ejectors and the defroster assemblies.

Installation Instructions (cont'd)

Installation Procedures (cont'd)

6. Connect Flight Deck Heater Ejectors to plumbing and locate ejectors.

Note

Location of Flight Deck heaters is determined
After connection to plumbing (see Dwg S76H-906).

7. Locate and install defroster assemblies.
8. Connect plumbing to cabin heaters and locate Cabin Heater Ejectors.
9. Complete Cabin Heater installation.
10. Tighten all plumbing fittings and leak check using "shop air."
11. Drill two .50 Dia holes in floor panel for valve stem access. Also notch floor panel as required to provide clearance for the S-9837-8 Tube Assembly (Station 120). Edge seal all panel "cutouts" according to Sikorsky Service instructions.

Weight and Balance Data

Adjust aircraft licensed empty weight and CG as follows:

<u>Item</u>	<u>P/N</u>	<u>Wt.</u> <u>lb.</u>	<u>Arm</u> <u>(in)</u>	<u>Moment</u> <u>(In-lbs.)</u>
Flight Deck Heater/Windshield Defroster	S76H-100-* **	33.00	110.5	3646
Cabin Heater	S76H-100-16	6.51	132.6	863
Flight Deck Htr/Defroster and Cabin Heater	S76H-100-* & S76H-100-16	39.51	114.1	4509

*: -7,8,9,10,11&12, the difference in weights between each installation is negligible.

** : -9, -10, -17, -18, 19 & -20, the difference in weights between each installation is negligible.

Service Manual Supplement

AIR COMM CORPORATION
Boulder, CO 80301

Document No. S76H-200M

INSTRUCTIONS FOR CONTINUED AIRWORTHINESS

for the

Sikorsky S-76 Cabin Heater

September 27, 1994

Service Instructions
Table of Contents

<u>Item</u>	<u>Page</u>
Revisions	i
Introduction	2
Reference Documents	2
System Description & Operation	2
Maintenance Instructions	3
Spares List	4
Appendix A	A-1
Service Instructions SI-S76H-6 Removal & Replacement Procedures – Heater Ejector Acoustical Foam	

INTRODUCTION

This document provides maintenance and service information for the ACC S76H-100 cabin heater installation in the Sikorsky S-76 series helicopter.

REFERENCE DOCUMENTS

1. Sikorsky Service Instructions.
2. AC43.13.1A, Acceptable Practices, Aircraft Alternation and Repair.
3. ACC Drawings:
 - S76H-100; General Arrangement – Sikorsky S76 Cabin Heater
 - S76H-505; S-76A Bleed Air Plumbing Installation (Previously equipped with Cabin Heater)
 - S76H-508; S-76B Bleed Air Plumbing (Previously equipped with an ECU)
 - S76H-505; S-76A Bleed Air Plumbing (Previously equipped with an ECU)
 - S76H-526; S-76C Bleed Air Plumbing (Previously equipped with a cabin heater)
 - S76H-906; Flight Deck Heater Installation
 - S76H-925; Cabin Heater Installation
 - S76H-965; Windshield Defroster Installation

SYSTEM DESCRIPTION AND OPERATION

The ACC cabin heating system is a “bleed air” type, which consists of bleed air plumbing, a manually controllable bleed airflow control valve, and ejectors. This system is shown schematically on page 5 of 5.

The ACC heater system is installed either as an addition or as a replacement for the existing factory installed heater or ECU.

The original factory bleed air plumbing to the heater or ECU connection is retained. This includes the engine bleed port restrictors, check valves, firewall shutoff valve and stainless steel flex hose.

MAINTENANCE INSTRUCTIONS

Conduct the following inspection functions in conjunction with Sikorsky standard interior inspection practices. All inspections must not extend beyond two years from the previous inspection.

1. Inspect valves for – mounting security, leakage (some leakage is acceptable), and freedom of operation.
2. Inspect bleed plumbing for corrosion, insulation and security.
3. Verify security of control knobs and placards.
4. Remove Heater Ejectors. Inspect Nozzles for evidence of deterioration.
5. Verify that all placards are located where required.
6. Remove and replace the Acoustical Foam Liner from the S-9802 and S-6460 Ejector Assemblies if deterioration is evident.
7. Verify function and operation of the S-9230EC-1 Drain Valve Assembly. The valve should be disassembled, cleaned, and inspected for corrosion. The valve should open so that it will allow water to drain at or below 10 psi. The valve should be closed at pressures above 10 psi.

Note

The ACC cabin heater system is installed in combination with components of the original Sikorsky heater system. Therefore, the related sections of the Sikorsky Service Instructions are applicable when the ACC system is installed.

Maintenance Instructions (cont'd)

Spares List

<u>Item No.</u>	<u>Description</u>	<u>P/N</u>
1	Heater Defroster Valve Assy	S-9877-3
2	Placard (Flt Deck Htr)`	S-9868-1
3	Placard (Defroster)	S-9868-2
4	Placard (Heater)	S-9868-3
5	Placard (Heater operating instructions)	S-9868-4
6	Flight Deck Heater Ejector	S-9802-3
7	Cabin Heater Ejector (LH)	S-6460-1
8	Cabin Heater Ejector (RH)	S-6460-2
9	Defroster Ejector (LH)	S-9828-1
10	Defroster Ejector (RH)	S-9828-2
11	Drain Valve Assembly	S-9230EC-1

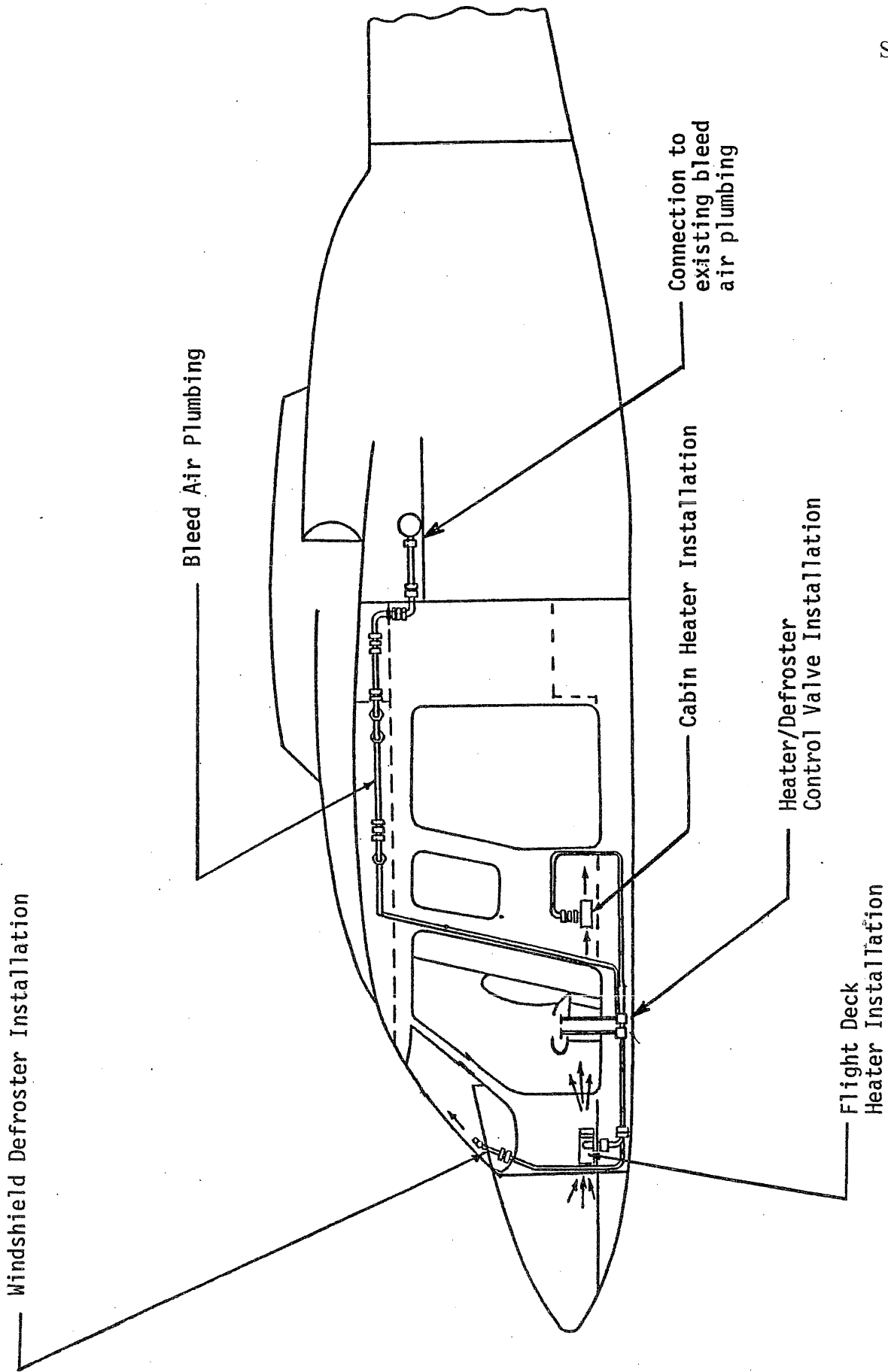

General Arrangement - S76H-100 Cabin Heater System

SERVICE INSTRUCTIONS

No. SI-S76H-6

Date: October 17, 1995

Subject: Removal and Replacement Procedures – Heater Ejector Acoustical Foam

Applicability: S-76A, S-76B & S-76C Helicopters which are equipped with the ACC S76H-100 Cabin Heater System.

References:

Air Comm Corporation drawing S76H-100
FAA STC No. 4057NM

Effectivity:

Compliance with the rework instructions specified in this document is at the discretion of the operator.

Discussion:

The referenced cabin heater ejector assemblies are lined with a special acoustical Foam Rubber. This material is bonded in place using RTV.

It has been determined that the foam rubber degrades after several years of service.

It is recommended that this material be replaced periodically to ensure proper operation of the Heater Ejectors.

SI-S76H-6 Kit List

<u>Item</u>	<u>P/N</u>	<u>Description</u>	<u>Qty Rqd</u>
1	S-9802-50	Ring	2
2	S-9802-41	Pad	2
3	S-6460EC-19	Pad	4
4	S-6460EC-20	Pad	2
5	S-6424EC-15	Pad	2
6	AA32R	Rivet	4

Rework Instructions;

1. Thoroughly clean the Acoustical Foam faying surfaces prior to bonding. Wipe with MEK or Isopropyl Alcohol.
2. Bond Acoustical Foam parts in position shown using RTV.

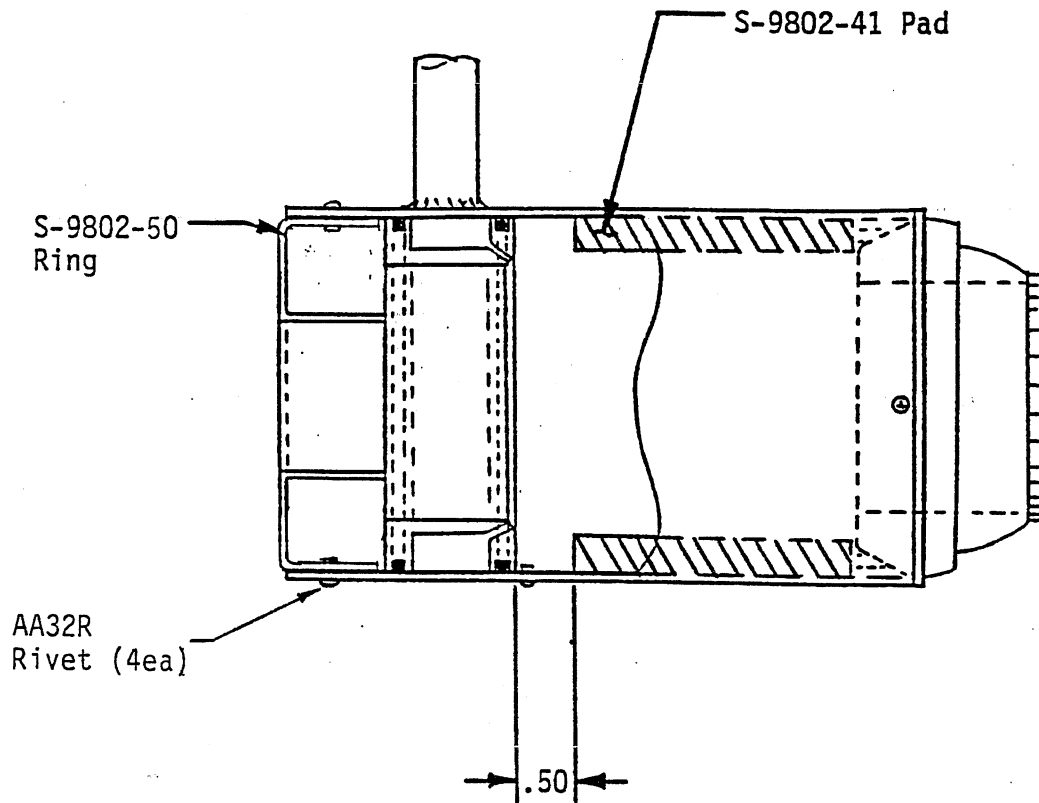

S-9802EC-3 Ejector Assembly

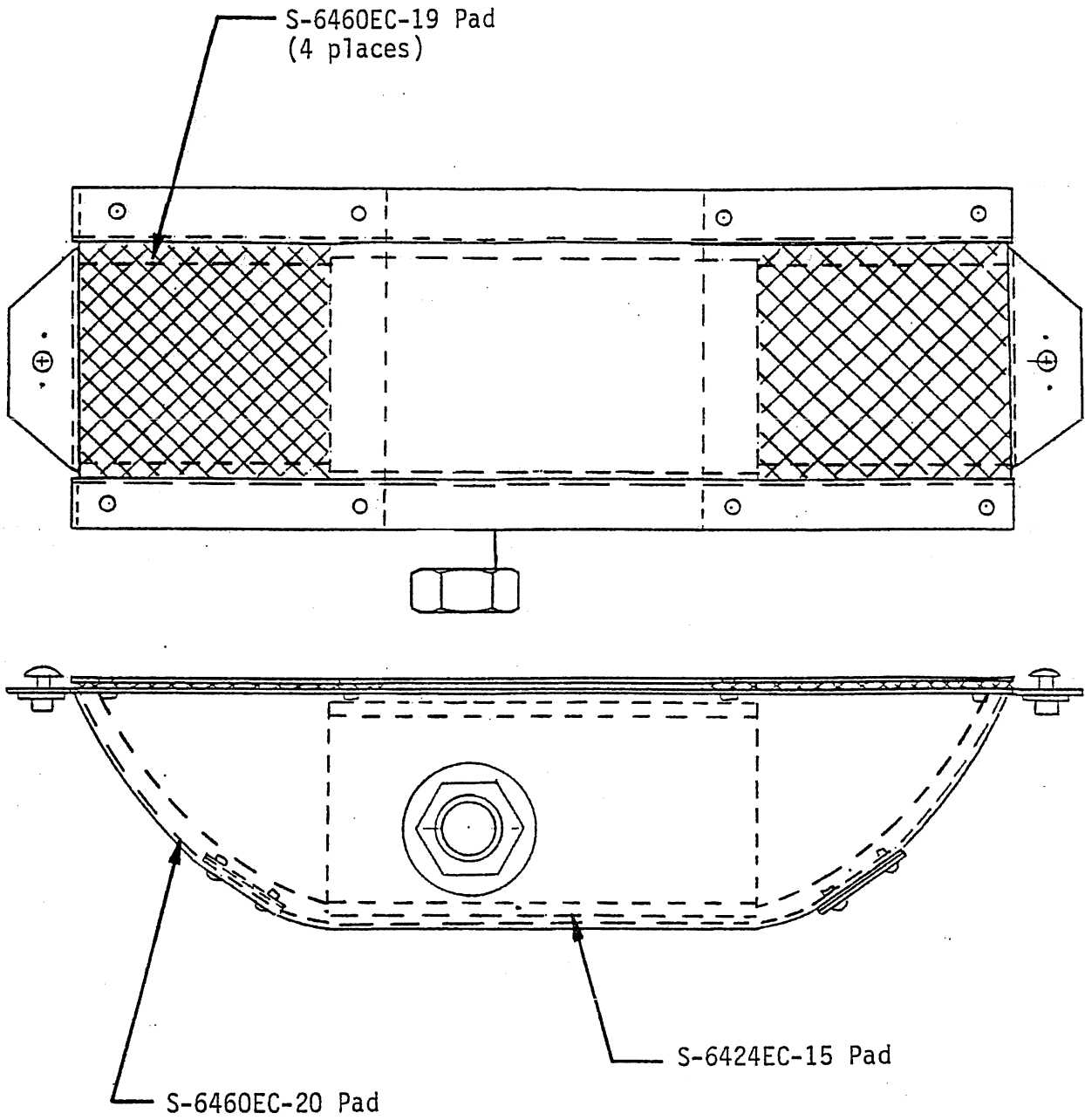

S-6440EC-2/-3 Heater Assembly

Flight Manual Supplement

AIR COMM CORPORATION
BOULDER MUNICIPAL AIRPORT
3300 AIRPORT ROAD
BOULDER, CO 80301

SIKORSKY *
MODELS S-76A, S-76B & S-76C

FLIGHT MANUAL SUPPLEMENT
FOR
BLEED AIR CABIN HEATER

S76H-100

FAA APPROVED

The information contained in this document is FAA approved material, which must be carried in the basic Flight Manual after the rotorcraft has been modified by installation of the cabin heater system in accordance with Air Comm Corporation, STC No. SH4-57NM.

The information in this document supplements or supersedes the basic manual only in the items contained herein. For limitations, procedures, and performance data not contained in this supplement, consult the basic Flight Manual.

*Includes S-76A modified by installation of Arriel engine (see Sikorsky STC SH568NE).

REVISED DEC 16 1994
FAA APPROVED 10/04/89

1 of 10

MODEL S-76A, S-76B & S-76C
FLIGHT MANUAL

Bleed Air Cabin Heater

LOG OF PAGES			
Original.....0			
Pages	Rev No.	Pages	Rev No.
1-10	N/C		
Approved: <u>Michael H Borfitz</u> Michael H. Borfitz, Supervisor Denver Aircraft Certification Field Office Northwest Mountain Region, Aurora, CO			

MODEL S-76A, S-76B & S-76C
FLIGHT MANUAL

Bleed Air Cabin Heater

LOG OF REVISIONS			
No.	Rev Date	Pgs Revised	FAA Appl.
0	10/04/89	Original Issue	A. B. Bofie
1	12/22/89	All pgs	M. H. Dorfitz
2	04/20/90	Pg 5, 6, & 7	M. H. Dorfitz
3	04/24/91	Pg 7	O. E. Green
4	12/16/94	All Pages	<i>[Signature]</i>

Note: Revision are indicated by a black vertical line.

FAA APPROVED 10/04/89
REVISED 12/16/94

MODEL S-76A, S-76B & S-76C
FLIGHT MANUAL

Bleed Air Cabin Heater

Introduction

The S-76H-100 cabin heating system is a bleed air type which consists of a bleed air plumbing system, a manually operated heater control valve and a system of heater ejectors. The system also includes a windshield defroster system. The system general arrangement is shown by Figure 1.

The system is available as a flight deck heater and windshield defroster system. An optional cabin heater system is also available.

The system is approved for installation as a supplement to the existing bleed air heater or ECU, or with the existing system removed. If the factory installed heater system is removed, the bleed air shut-off valves must be retained. In addition, the heater "low bleed air pressure" system is retained. This system includes the engine bleed low pressure switch, the heater shutoff valves, and the engine bleed air advisory light system. This system automatically shuts the heater system off, in case of low engine bleed pressure, or loss of engine power.

In addition, the cabin ventilation blower, inlet flapper valve, and overhead ducting system is also retained.

Bleed air flows from the engine compressors through the heater ON-OFF valves, the bleed air plumbing, and the heater control valves to the heater ejectors. The heater ejector mix cabin air with the bleed air and exhaust the warm air to the cabin and across the windshield. The air is circulated by the pumping action of the ejectors.

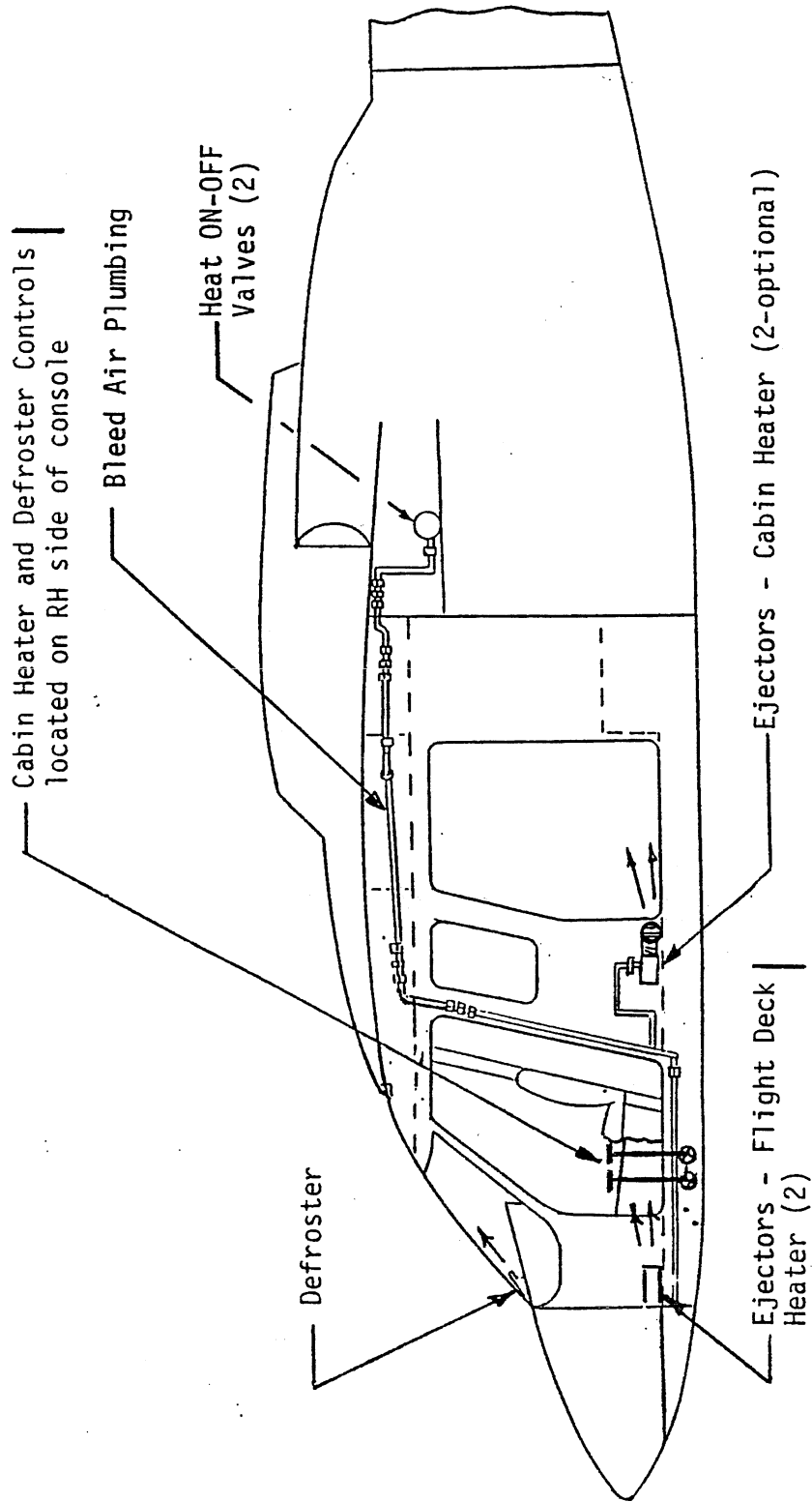

Figure 1, General Arrangement - S-76 Cabin Heater System

MODEL S-76A, S-76B & S-76C
FLIGHT MANUAL

Bleed Air Cabin Heater

Section I

Operating Limitations

Placards and Markings:

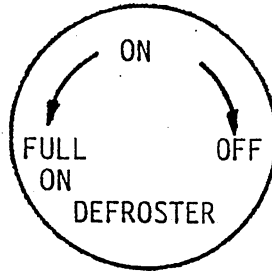
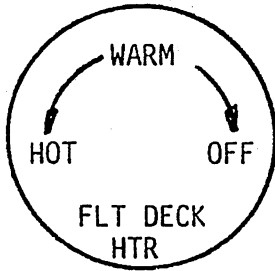

Locate on heater control knobs.

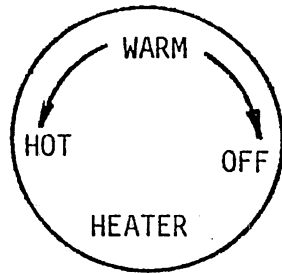

Alternate heater placard if optional cabin heater is installed



If optional cabin heater is installed: locate on LH & RH side panels directly above heater inlets and outlets (4 total).

MODEL S-76A, S-76B & S-76C
FLIGHT MANUAL

Bleed Air Cabin Heater

Section I

Operating Limitations

Placards and Markings

**CABIN HEATER
OPERATING INSTRUCTIONS**

1. Turn Bleed Air Switch ON.
2. Turn Heater or defroster On as Desired.

NOTICE

* Max Defroster output is achieved with both original and ACC Heater On.

AIR COMM CORPORATION

Locate on center console adjacent to Heater & Defroster controls.

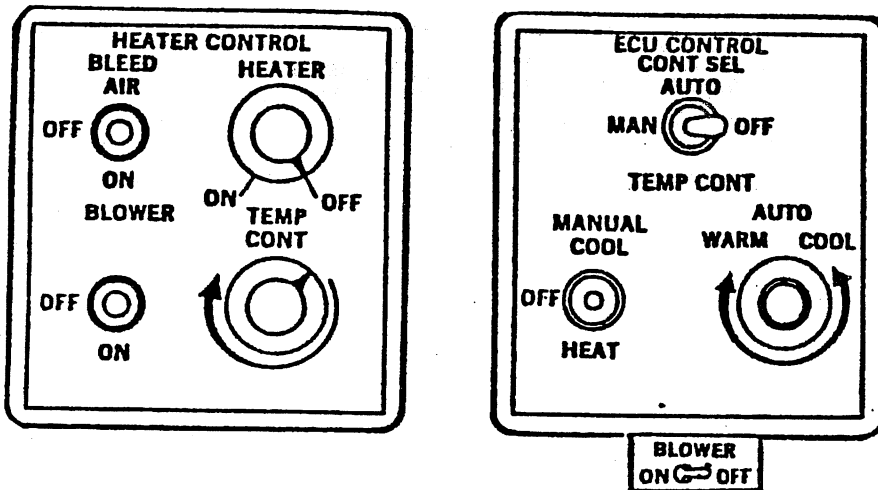

Existing Heater or ECU Control Panels if system is retained

MODEL S-76A, S-76B & S-76C
FLIGHT MANUAL

Bleed Air Cabin Heater

Section I (cont'd)

Operating Limitation

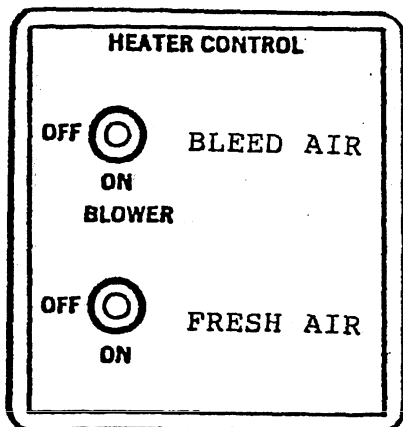

Overhead control panel if factory heater has been removed.

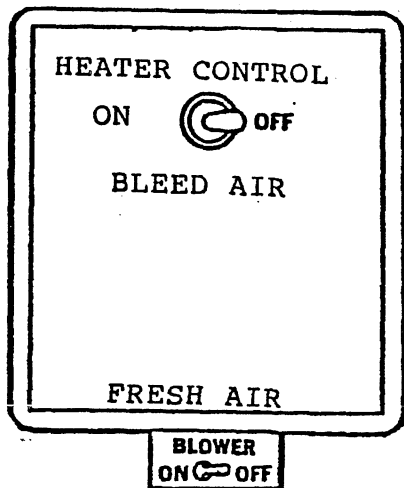

Overhead control panel if factory ECU has been removed.

REVISED DEC 16 1994
FAA APPROVED 10/04/89

FAA APPROVED
SUPPLEMENT

MODEL S-76A, S-76B & S-76C
FLIGHT MANUAL

Bleed Air Cabin Heater

Section II

Normal Procedures

Engine Prestart check

Heater control bleed air switch OFF.
Cabin heater valve OFF.
Defroster valve OFF.

Before take-off

Heater control bleed air switch OFF.
Cabin heater valve OFF.
Defroster valve OFF.

In-flight Operations

Heater control bleed air switch ON.
Cabin Heater Valve ON as desired.
Operate factor installed bleed air heater of ECU as desired
(if system has not been removed).

NOTE

The electrically operated bleed air valves, which are
located at each engine, will automatically close if power is
lost on either engine.

Decent and Landing

Heater control bleed air switch OFF.
Cabin heater valve OFF.
Defroster valve OFF.

REVISED
FAA APPROVED

DEC 16 1994
10/04/89

9 of 10

FAA APPROVED
SUPPLEMENT

MODEL S-76A, S-76B & S-76C
FLIGHT MANUAL

Bleed Air Cabin Heater

Section III

Emergency Procedures

Operate the heater control bleed air switch and the cabin heater and defroster valves to OFF for any of the following emergencies:

- Engine failure.
- Engine over-temperature.
- Insufficient power.
- Onboard fire.

Section IV

Malfunction Procedures

No change.

Section V

No change in performance with heater OFF. Basic Flight Manual performance cannot be achieved with heater and/or defroster on.

STC Certificate

United States of America
Department of Transportation—Federal Aviation Administration

Supplemental Type Certificate

Number SH4057NM

This certificate, issued to Air Comm Corporation

certifies that the change in the type design for the following product with the limitations and conditions therefor as specified hereon meets the airworthiness requirements of Part 29 of the Federal Aviation Regulations.

Original Product—Type Certificate Number: H1NE
Make: Sikorsky Aircraft
Model: S-76A, S-76B, S-76C

Description of the Type Design Change:

Installation of bleed air cabin heater and windshield defrost system in accordance with Air Comm Corporation Drawing List DL-S76H, Revision H, FAA approved December 15, 1994, or later approved revision.

Limitations and Conditions:

1. FAA Approved Flight Manual Supplement S76H-100, dated December 16, 1994, or later approved revision is required.
2. FAA Approved Flight Manual Supplement S76H-102, dated December 31, 1997, or later approved revision is required for the S-76C without the windshield defrost system installed.
3. FAA Approved Flight Manual Supplement S76H-104, dated May 14, 1998, or later approved revision is required when the windshield defrost and cockpit heater controls are common and a separate control is provided for cabin heat.
4. Approval includes Model S-76A with the Arriel engine installed in accordance with STC SH568NE.
5. Approval of this change in type design applies to the above model aircraft only. This approval should not be extended to aircraft of this model on which other previously approved modifications are incorporated unless it is determined that the relationship between this change and any of those other previously approved modifications, including changes in type design, will introduce no adverse effect upon the airworthiness of that aircraft. A copy of this Certificate shall be maintained as part of the permanent records for the modified aircraft.
6. If the holder agrees to permit another person to use this certificate to alter the product, the holder shall give the other person written evidence of that permission.
7. A copy of this Certificate and Flight Manual Supplements, or later FAA approved revision, must be maintained as part of the permanent records for the modified aircraft.

This certificate and the supporting data which is the basis for approval shall remain in effect until surrendered, suspended, revoked, or a termination date is otherwise established by the Administrator of the Federal Aviation Administration.

Date of application: September 5, 1989

Date reissued:

Date of issuance: October 4, 1989

Date amended: 12/22/89, 12/16/94, 12/31/97, May 14, 1998



By direction of the Administrator

Ronald F. May
RONALD F. MAY (Signature) Manager
Denver Aircraft Certification Office
Northwest Mountain Region, Denver, Colorado
(Title)

Any alteration of this certificate is punishable by a fine of not exceeding \$1,000, or imprisonment not exceeding 3 years, or both.

This certificate may be transferred in accordance with FAR 21.47.

Supplemental Type Approval

Number: SH95-44

This approval is issued to:

Air Comm Corporation
3300 Airport Rd.
Boulder, CO 80301
U.S.A.

Issue No.: 1

Approval Date: October 13, 1995

Issue Date: October 13, 1995

Responsible Region:

Headquarters

Aircraft/Engine Type or Model:

Sikorsky S-76A

Canadian Type Approval or Equivalent:

H-84

Description of Type Design Change:

Installation of bleed air cabin heater and windshield defrost system in accordance with FAA STC SH4057NM

Installation/Operating Data,
Required Equipment
and Limitations:

Installation of bleed air cabin heater and windshield defrost in accordance with Air Comm Corporation Drawing List DL-S76H, Revision A, FAA approved October 4, 1989, or later approved revision.

Required Equipment

1. FAA approved Flight Manual Supplement dated October 4, 1989, or later approved revision.

Limitations

1. Approval includes Model S-76A with the Arriel engine installed in accordance with Supplemental Type Approval SH92-35, (Supplemental Type Certificate SH568NE).

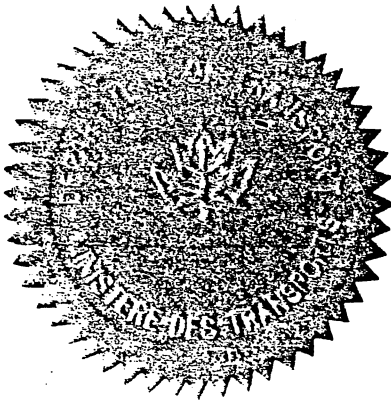

Conditions: This approval is only applicable to the type/model of aeronautical product specified therein. Prior to incorporating this modification, the installer shall establish that the interrelationship between this change and any other modification(s) incorporated will not adversely affect the airworthiness of the modified product.

F. R. Davies

Airworthiness Branch Ottawa
For Minister of Transport

Canada

55-3

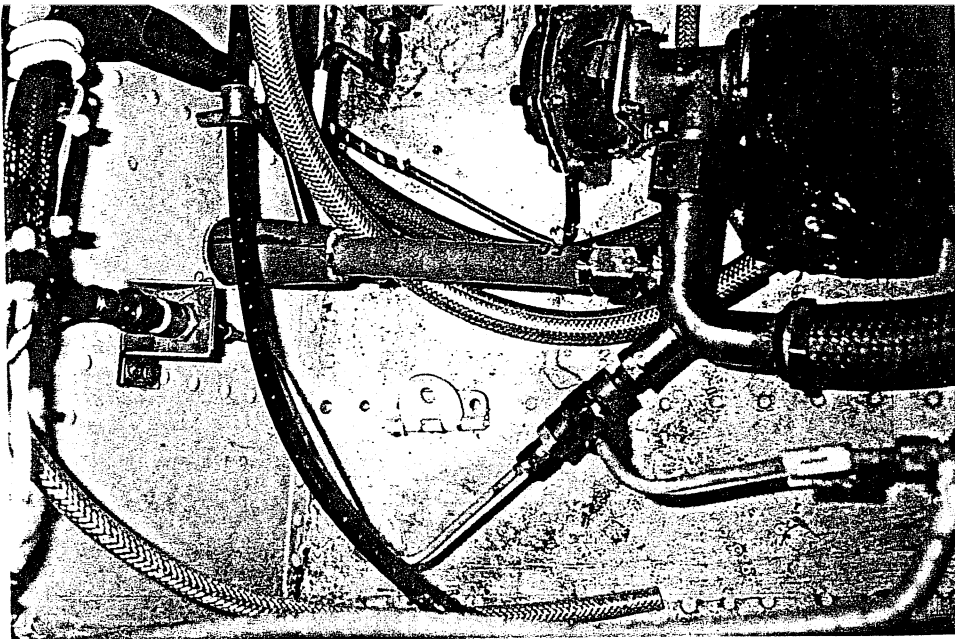

No. 52-21A

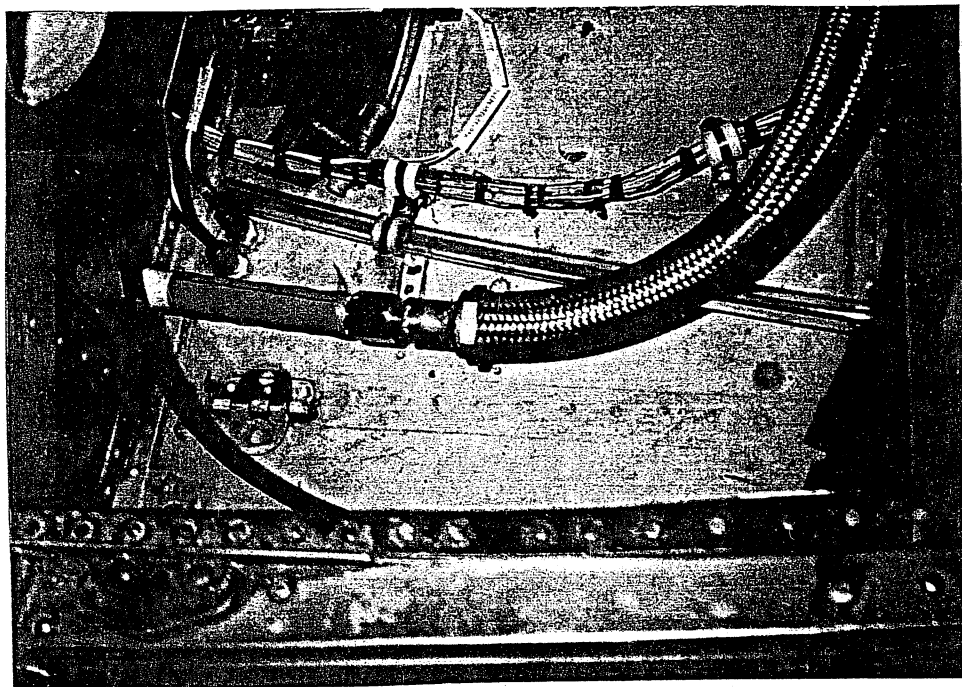

No. 53-3A

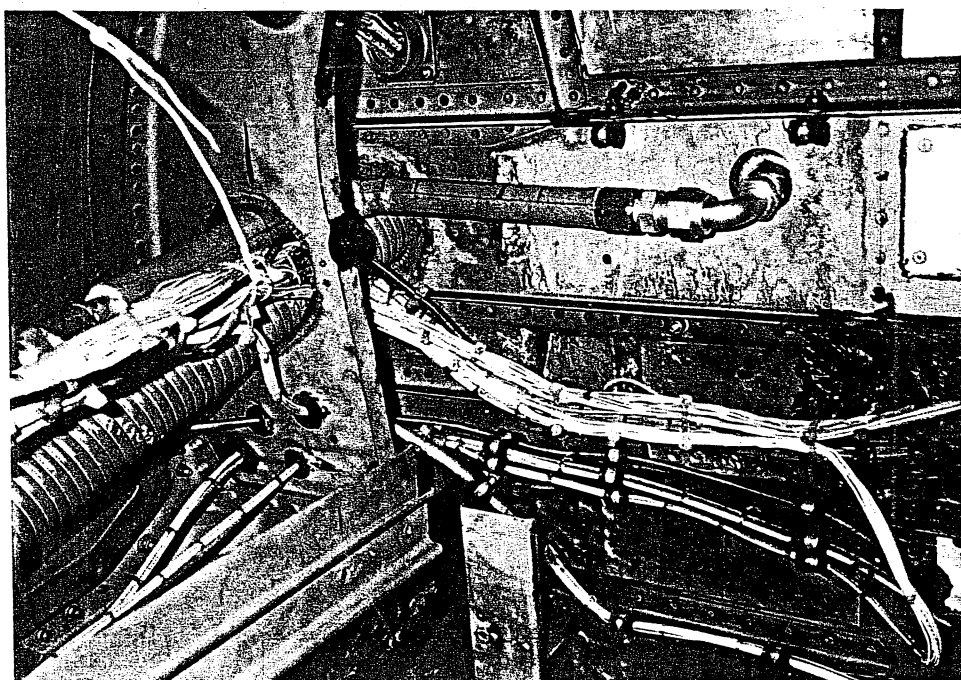

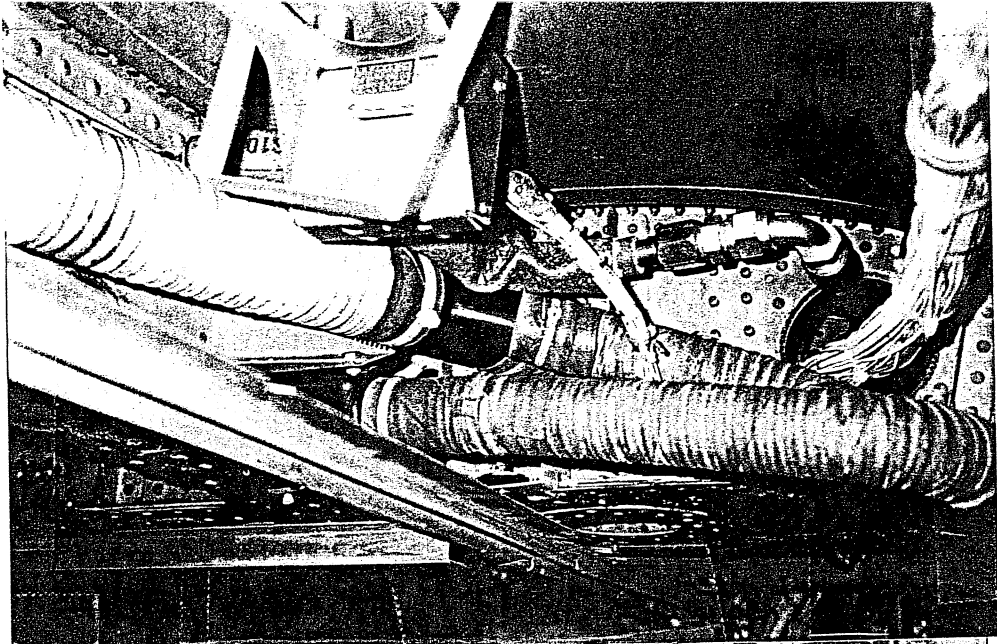

Page 5
S76H-200M

No. 53-5A

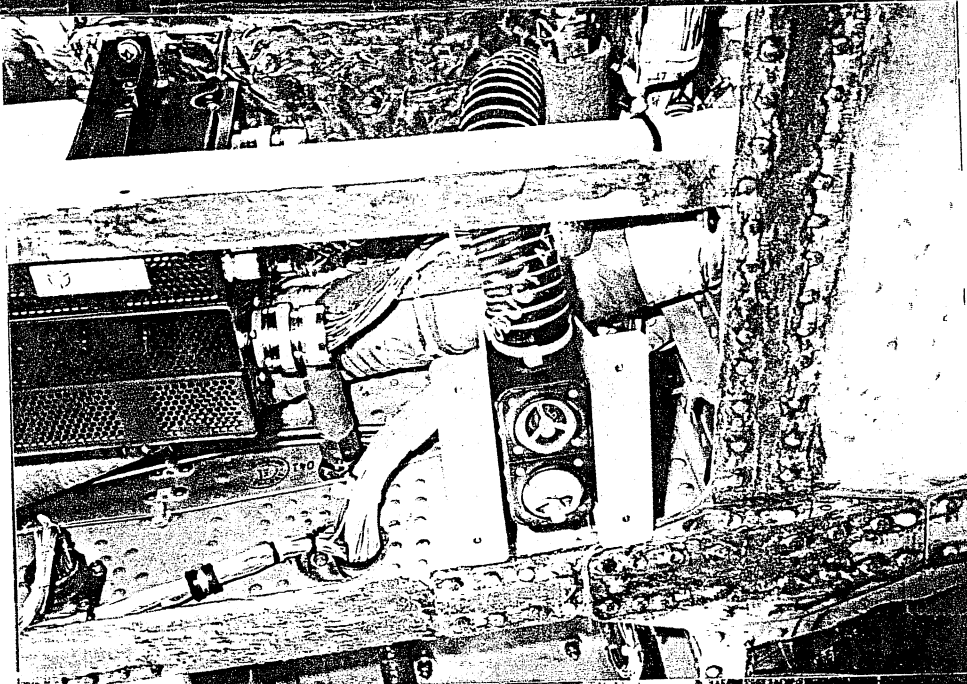

No. 181-3B

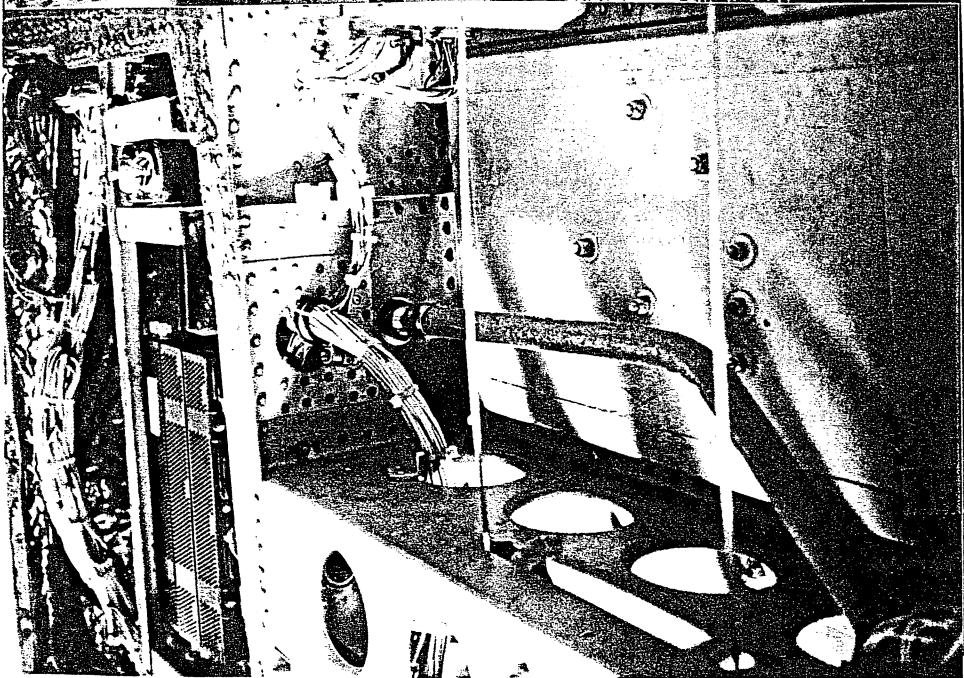

No. 181-4A

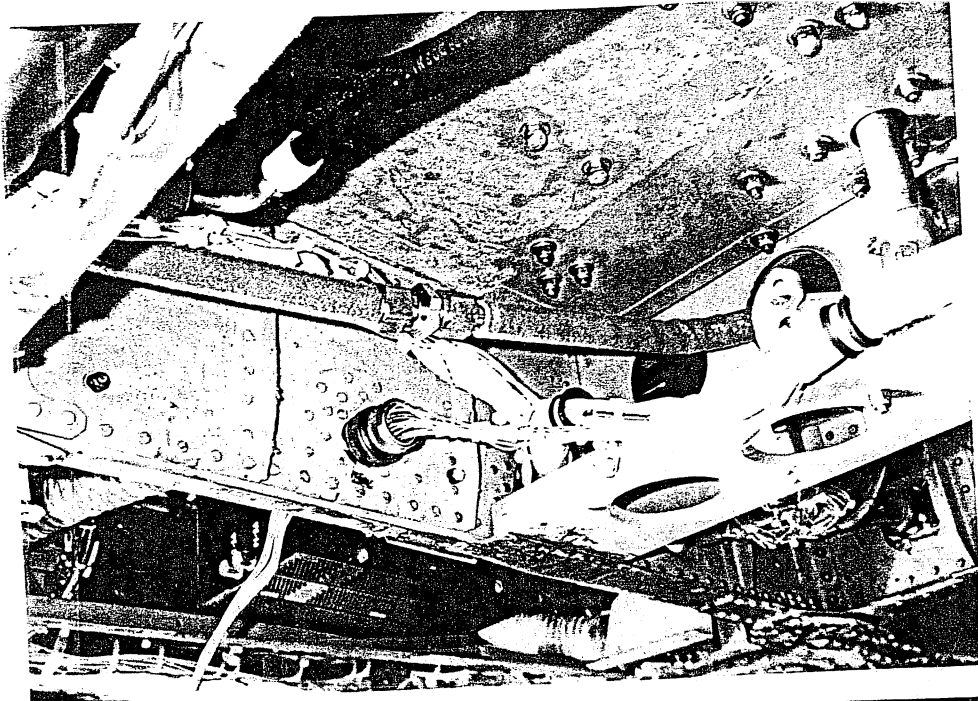

181-7A

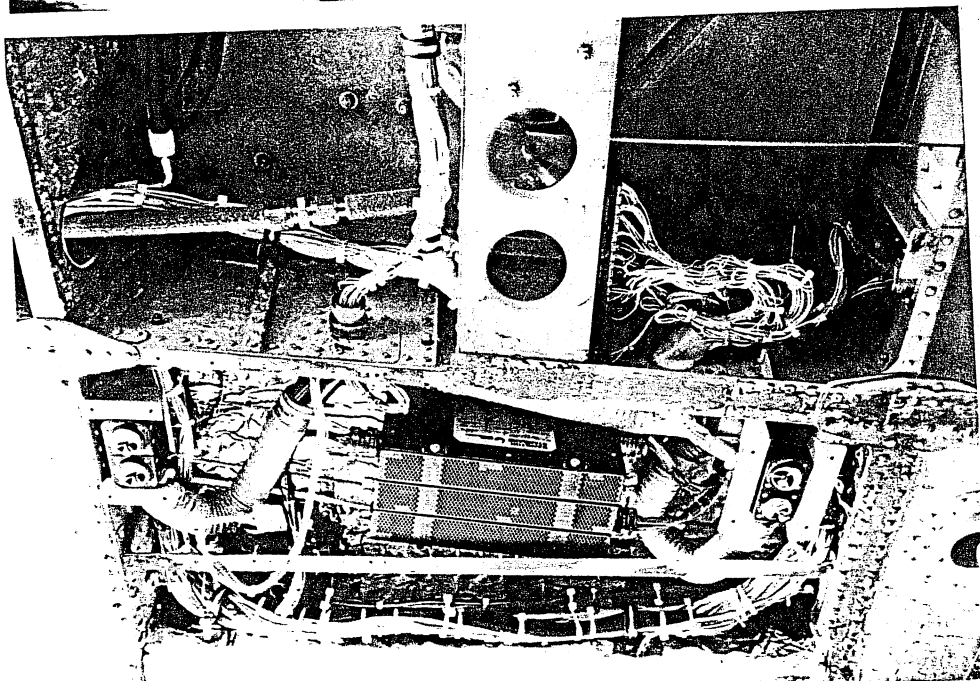

181-7B

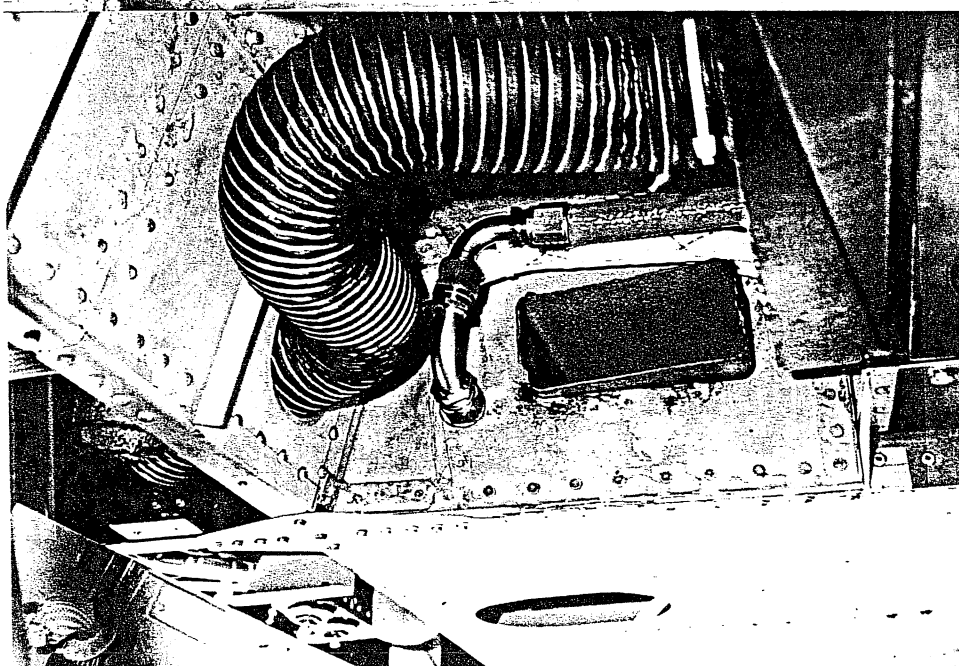

181-8B

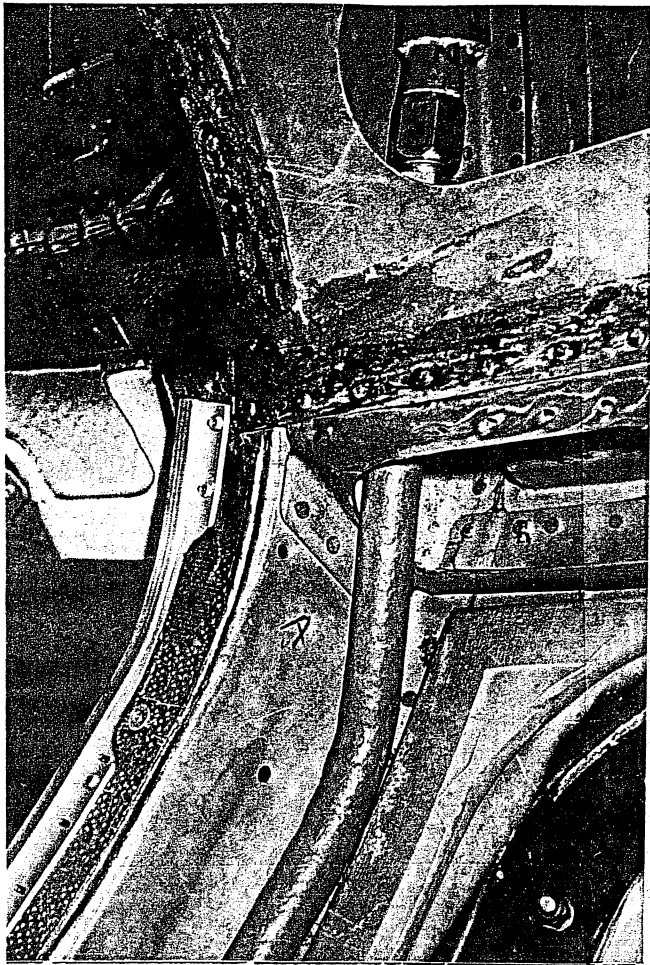

No. 53-16A

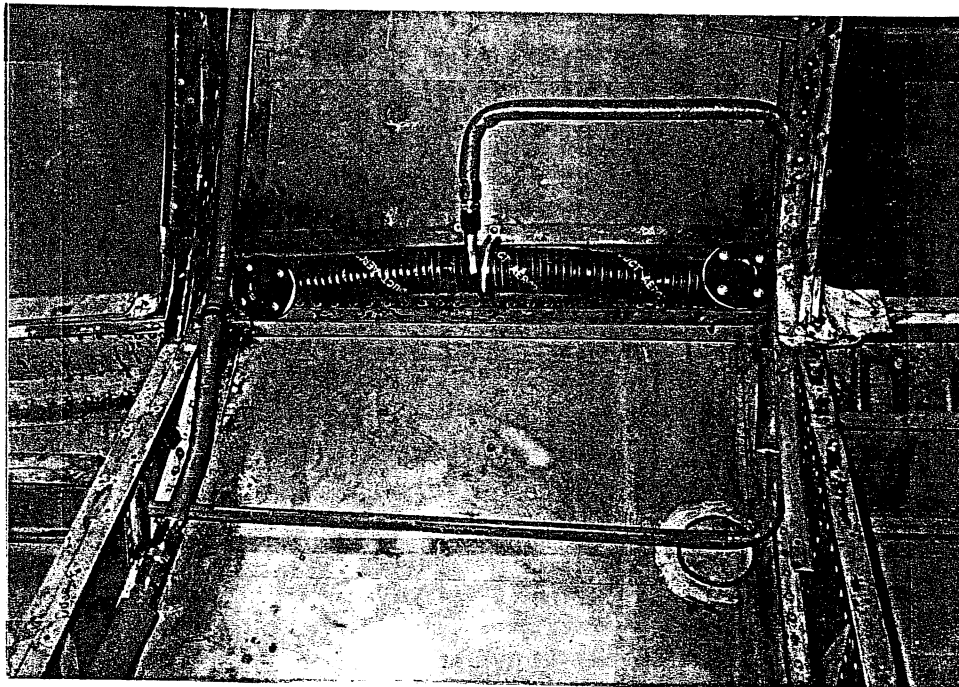
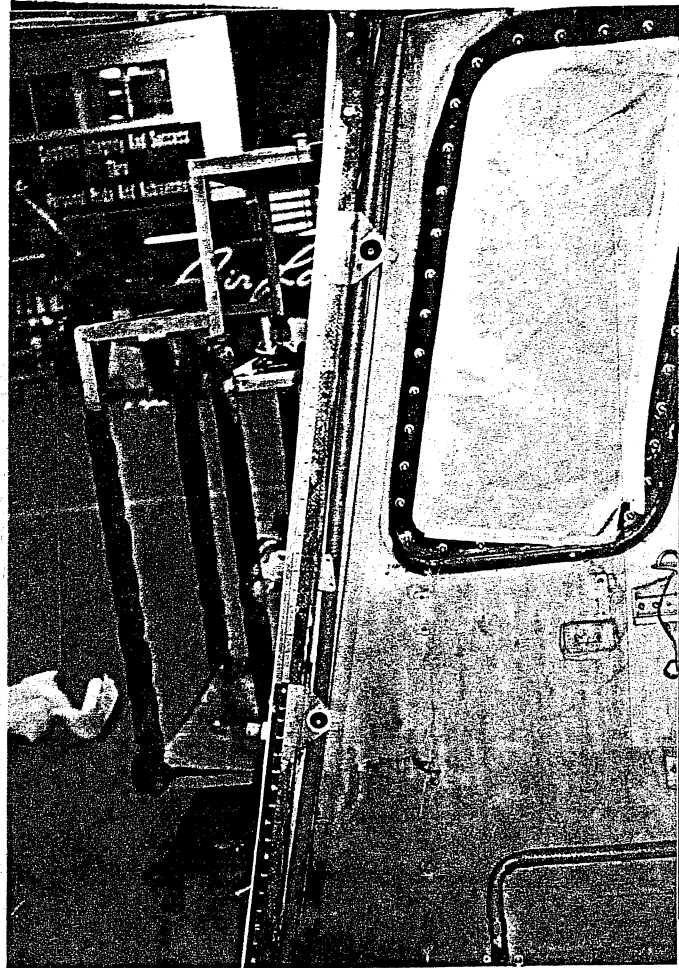

No. 53-14A

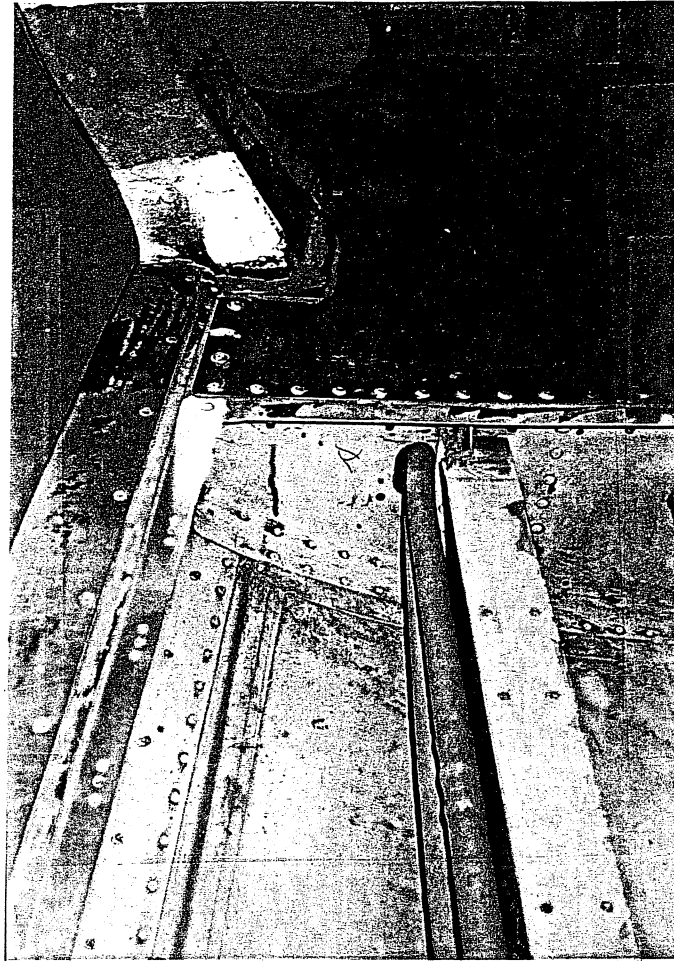

No. 52-17A

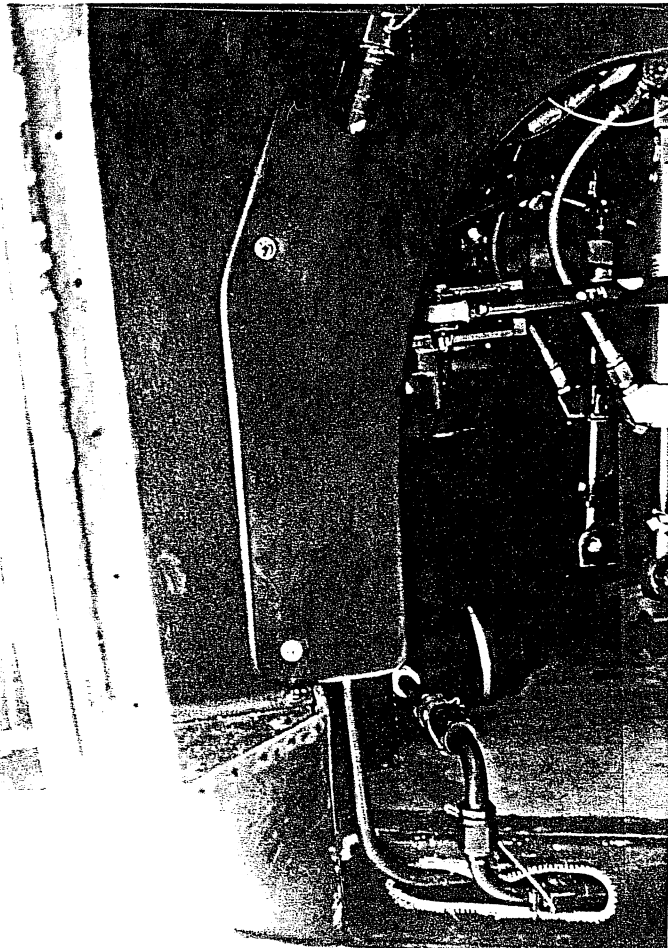

No. 181-18A

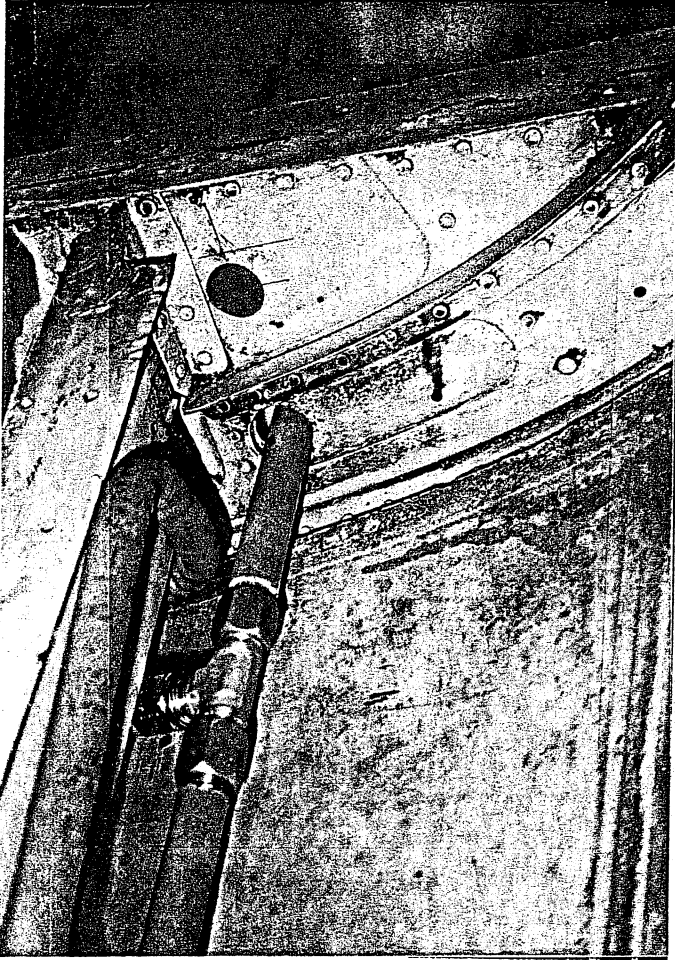

No. 52-18A

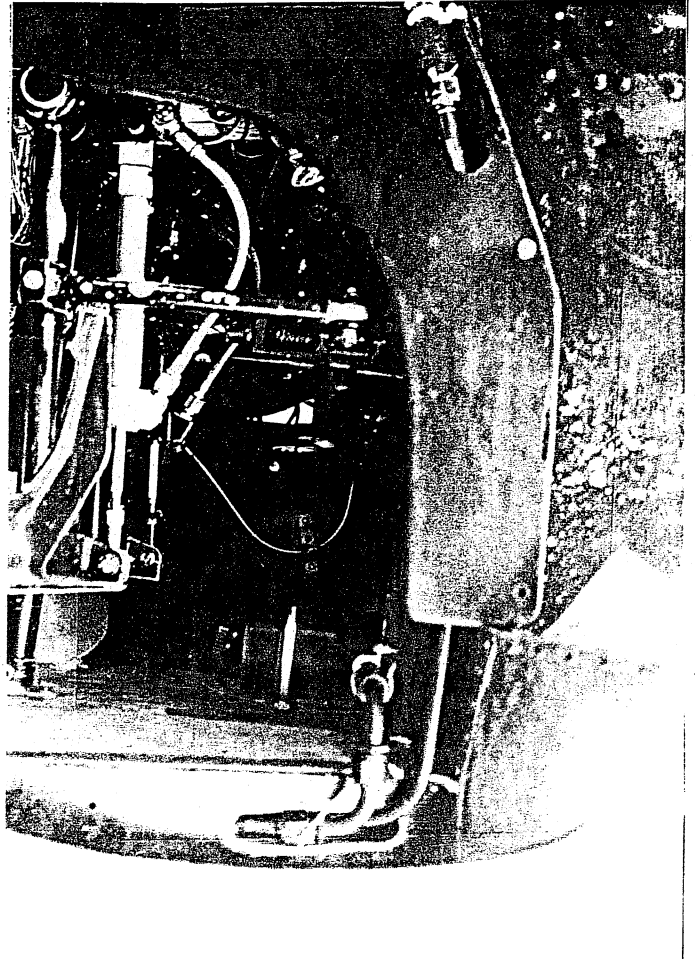

No. 181-14B

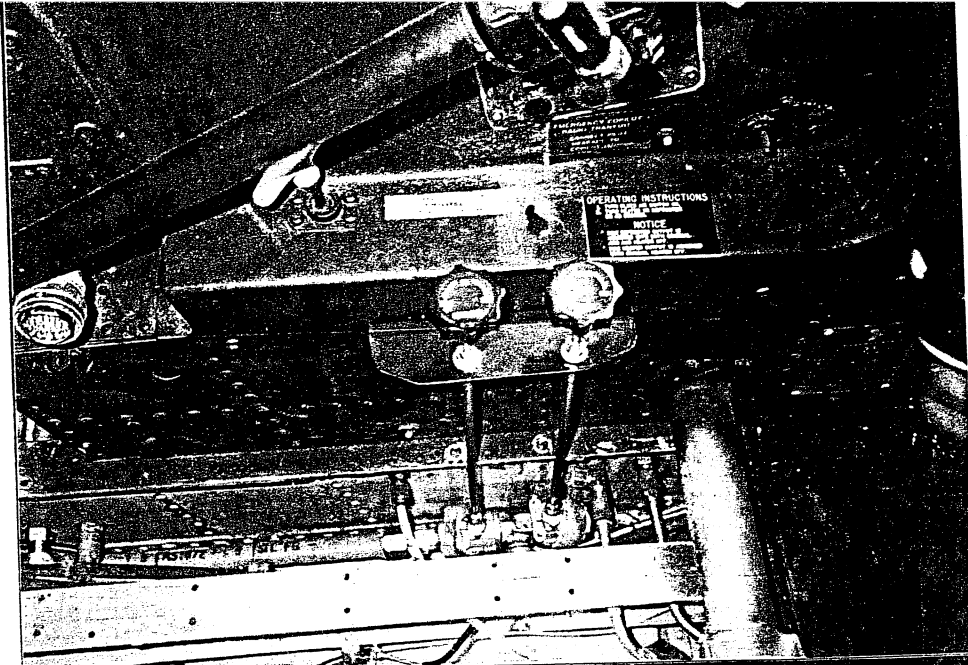

Page 10
S76H-200M

No. 52-22A

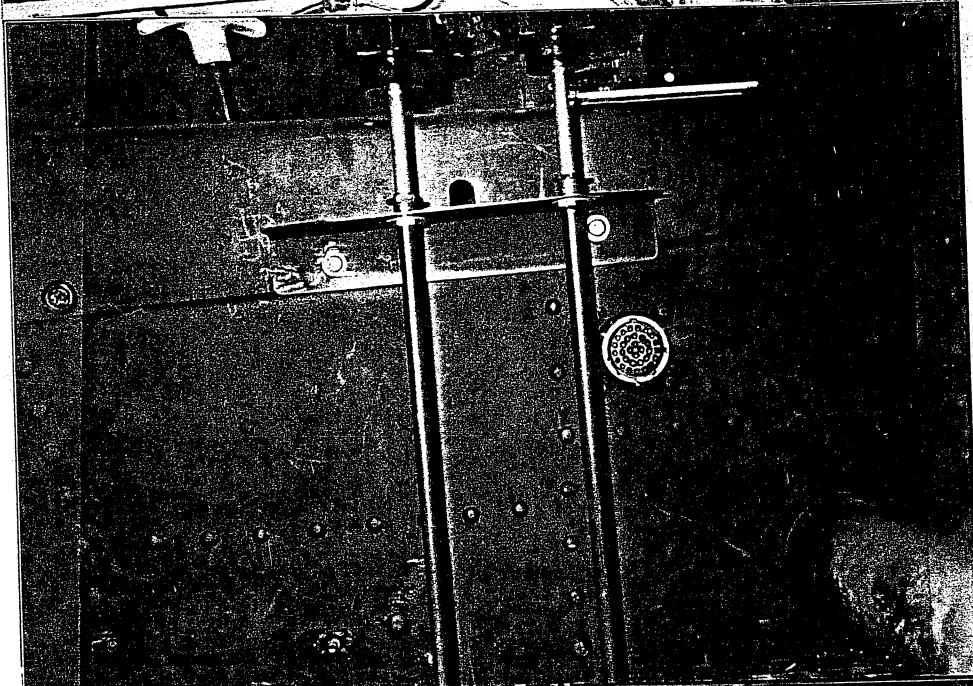

No. 52-20A

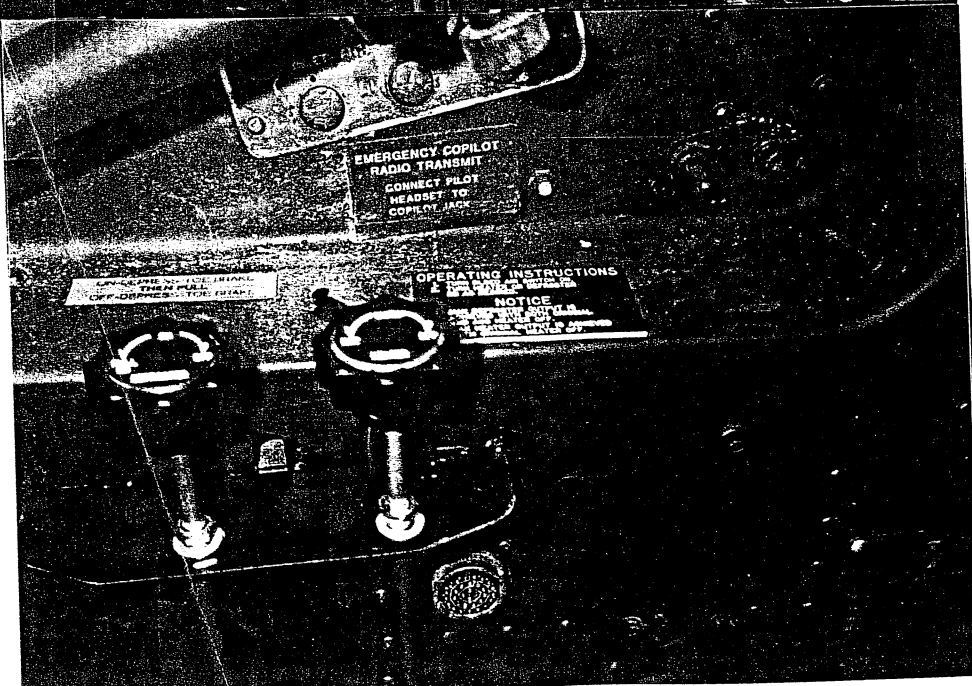

No. 52-5A